

# TYPE 512 OSCILLOSCOPE INSTRUCTION MANUAL



TEKTRONIX, INC.  
MANUFACTURERS OF CATHODE-RAY AND VIDEO TEST INSTRUMENTS

Sunset Highway and Barnes Road • P. O. Box 831 • Portland 7, Oregon, U. S. A.  
Phone: Cypress 2-2611 • Cables: Tektronix

TYPE 512 SERIAL NO. 2581

SERIAL NO. \_\_\_\_\_

### **IMPORTANT**

Include the INSTRUMENT TYPE and SERIAL NUMBER in any correspondence regarding your instrument. Your help in this will enable us to answer your questions or fill your order with the least delay possible.

### **NOTE**

This instruction manual has been prepared to cover TEKTRONIX Type 512 Oscilloscopes of all serial number ranges. Text, diagrams, and parts lists have been expanded to incorporate all circuit modifications adopted during the course of manufacture. The serial ranges of instruments to which various modifications were applied before shipping from the factory have been noted wherever necessary.

However, because many instruments have been modified in the field and out of serial sequence, component values and circuitry of a given instrument may differ considerably from those indicated in this manual for its serial number. The user is urged, therefore, to enter whatever changes may be necessary to bring this manual into agreement with the present circuitry of his oscilloscope.

When ordering parts, always include the following information: 1. Instrument Type (512). 2. Instrument Serial Number (as, SN 9999). 3. Part Circuit Number (as, R999). 4. Part Description (value, type, rating, tolerance, etc.). 5. The 6-digit TEKTRONIX part number (as, 999-999).

Replacement parts will be billed at current net prices and shipped prepaid by air to any point within the continental United States or Canada.

All price revision and design modification privileges reserved.

# CONTENTS

	Page
GENERAL DESCRIPTION	1
Characteristics. Functions of controls and Binding Posts.	
OPERATING INSTRUCTIONS	5
Horizontal Deflection System Adjustment of Sweep Stability. Function of Trigger Selector. Adjustment of Trigger Amplifier. Adjustment of Sweep Rate. Recurrent Sweep. Single Sweep. Blanking. External Sweep Input. Sweep Magnifier. Delayed Trigger. Sweep Output. Gate Output.	
Vertical Deflection System Vertical Amplifier. Differential Amplifier. Standardized Input Impedance. Direct Connection to Deflection Plates. High Frequency Operation. Time Marker Input. Calibration. Intensity Modulation.	
CIRCUIT DESCRIPTION	11
Cathode Ray Tube Circuits. Horizontal Deflection System. Vertical Deflection System. Power Supply.	
ADJUSTMENTS AND MAINTENANCE	23
Replacement of Components. Removal of case. Operation on 210-250-Volt 50-60-Cycle Line. Power Supply. Calibrator. Vertical Amplifier. Horizontal Deflection System.	
DIAGRAMS AND PARTS LIST	29
Block Diagram. Sweep, Calibrator and CRT. Vertical Amplifier. Power Supply. H.V. Supply.	
MISCELLANEOUS PARTS	73
ACCESSORIES FOR TEKTRONIX INSTRUMENTS	

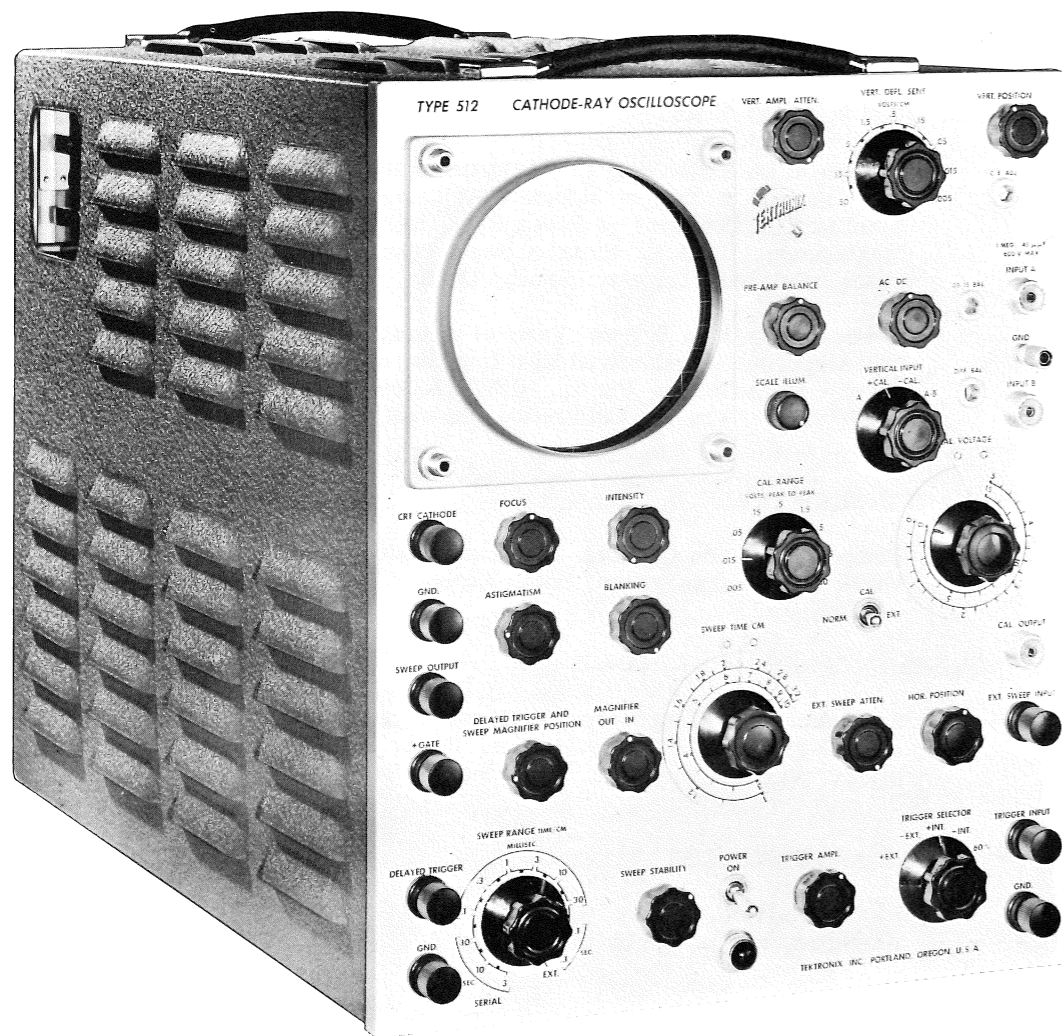

## GENERAL DESCRIPTION

The Type 512 is a portable precision laboratory instrument incorporating dc coupled amplifiers throughout. Its sensitivity of 5 mv/cm dc and sweeps as slow as 0.3 sec/cm solve many problems confronting workers in the fields where comparatively slow phenomena must be observed. The vertical bandwidth of 1 mc at maximum sensitivity (2 mc at lesser sensitivity) and sweeps as fast as 3  $\mu$ sec/cm make it an excellent general purpose oscilloscope as well.

## CHARACTERISTICS

### Signals Observable

1. Sine waves from 1/3 cps to above 500kc.
2. Pulses of 1  $\mu$ sec to 3 seconds.

### Sweep Circuit

Phantastron followed by push-pull linear amplifier. Triggered, recurrent or single sweeps as desired.

### Sweep Speeds

Continuously variable from 0.3 sec/cm to 3  $\mu$ sec/cm in ten calibrated ranges. Calibration accuracy, plus or minus 5%.

### Magnification

Any desired 20% of the sweep can be spread over the entire trace.

### External Sweep Input

Via 100 k potentiometer and dc coupled amplifier. 1.0 v/cm maximum sensitivity (5ABP7) or 1.5 v/cm (5CP7).

### Trigger Requirements

Will trigger from signals being observed which produce deflection of 5 mm or greater. External triggers of either polarity. Square waves or sine waves 0.15 v to 50 v peak to peak, or pulses 0.15 v to 15 v peak (In instruments below SN 1985, 0.5 v minimum required).

### Vertical Deflection Sensitivity (peak to peak)

Direct to plate 13 v/cm (5ABP7) or 25 v/cm (5CP7). Via amplifier 5 mv to 50 v/cm. Sensitivity reduced by a factor of 10 when probe is used.

### Input Impedance

1 megohm shunted by 45  $\mu$ f. With probe 10 megohms and 14  $\mu$ f.

**CAUTION—IN NO CASE SHOULD THE COMBINED AC AND DC INPUT VOLTAGES EXCEED 600 VOLTS PEAK WITH EITHER DIRECT CONNECTION OR PROBE.**

### Vertical Amplifier Response

For sensitivities of 0.15 v/cm or lower: Bandwidth dc to 2 mc. Rise time 0.2  $\mu$ sec. For sensitivities between 5 mv and 0.15 v/cm: Bandwidth dc to 1 mc. Rise time 0.4  $\mu$ sec.

### Calibrating Voltage

Square wave of approximately 1 kc. Nine ranges 5 mv to 50 v full scale. Accuracy plus or minus 5%.

### Waveforms Available Externally

Sweep sawtooth, 100 volts peak.  
Delay trigger, 75 volts peak.  
Positive gate, 150 volts peak.



Square wave calibrating signal, 0-50 volts peak.

#### Connection to Crt Cathode

Via 0.1  $\mu$ fd capacitor. RC equals 0.01 sec.

#### Accelerating Voltage on Cathode-Ray Tube

3 kv.

#### Time-Marker Input

Via isolating stage to video amplifier. Minimum marker amplitude 8 v.

#### Power Requirements

105-125 volts, or 210-250 volts, 50-60 cycles, 280 watts. (See page 24)

#### Dimensions

15 1/2" high, 12 1/2" wide, 21 1/2" deep.

#### Finish

Panel, photo etched aluminum with black letters. Cabinet, gray wrinkle. Weight (including accessories) 54 lbs.

## FUNCTIONS OF CONTROLS AND BINDING POSTS

A brief explanation of the function of each control and binding post is given below. For a more detailed explanation see the Operating Instructions, Pages 5-10 and the Circuit Description, Pages 11-22.

**VERT. AMPL. ATTEN.**—Twin potentiometers R53 and R54 in cathodes of cathode followers V5 and V6 permit adjustment of gain of vertical amplifier over a 3 to 1 range.

**VERT. DEF. SENSITIVITY**—Gang switch SW3 controlling gain of vertical amplifier in steps of approximately 3 to 1. Connects two-stage preamplifier in circuit for three most sensitive positions.

**VERT. POSITION**—Potentiometer R56 connected between cathode of V7 and V8, determining operating points of these tubes. Because of the dc coupling, this shifts the image vertically.

**PRE-AMP BALANCE**—Potentiometer R20 provides a source of variable voltage which is applied to the plate of V2 via R19, permitting the plate potential of V2 to be varied positive or negative with respect to V1, as required, to balance the pre-amplifier output.

**AC-DC**—Gang switch SW2 inserting coupling

capacitors in the input circuit of the instrument and between the preamplifier and main amplifier, when dc coupling is not desired.

**INPUT A**—Input connector to vertical amplifier. Polarity is such that positive signal deflects beam upwards.

**GROUND**—Binding post connecting to chassis of instrument.

**INPUT B**—Input connector to vertical amplifier. Connects to grid opposite from Input-A grid. Negative signal deflects beam upwards. When VERTICAL INPUT switch is in position A, the B input is grounded.

**VERTICAL INPUT**—Gang switch SW1, connecting grids of amplifiers to permit either single-ended or push-pull input plus or minus calibration as follows:

A. INPUT A connected to amplifier grid (V1 or V5). Grid of V2 or V6 grounded.

+CAL. Square wave amplitude calibration signal connected to grid (V1 or V5). Increasing calibration voltage makes tops of square waves move upward.

-CAL. Same as +CAL. except calibration signal is applied to opposite grid so bottom of calibration square waves move downward.

A-B. INPUT A connected to one grid, INPUT B connected to opposite grid. Waveshape on crt shows difference between A and B signals.

**CRT CATHODE**—Binding post permitting connection of external modulating signals to the cathode of the cathode-ray tube via a 0.1  $\mu$ fd capacitor. RC equals 0.01 sec.

**FOCUS**—Potentiometer controlling the voltage applied to the focus anode (A1) of the crt and thereby the sharpness of the image.

**INTENSITY**—Potentiometer controlling bias on crt grid when the tube is unblanked and therefore controlling brightness of image.

**CAL. RANGE**—Attenuator for reducing amplitude of square wave calibrating signal. Steps correspond to ranges on CAL. VOLTAGE dial.

**CAL. VOLTAGE**—Potentiometer with calibrated dial for adjustment of calibrator square wave to desired amplitude.

**GROUND**—Connection to frame of instrument.

**ASTIGMATISM**—Potentiometer varying potential on Anode No. 2 with respect to the deflection plates. Correct adjustment of this control makes possible a sharp focus of the image in both horizontal and vertical planes simultaneously.

**BLANKING**—Potentiometer controlling the bias on the suppressor of V107 and therefore the amplitude of the blanking voltage applied to the crt grid.

**SWEEP OUTPUT**—Binding post connecting to

cathode of V113 providing sweep generator waveform at an amplitude of 100 volts.

**CAL. NORM.-EXT.**—Toggle switch making it possible to connect the calibrating square wave generator to either the vertical amplifier input or the calibrator output binding post.

**CAL. OUTPUT**—Binding post connected to arm of CAL. VOLTAGE potentiometer making the calibrating square wave available for external use.

**SCALE ILLUM.**—Variable resistor controlling brightness of the lamp which illuminates the plastic graticule over the face of the cathode-ray tube.

**+GATE**—Binding post for connection to the plate of V106 providing a positive gate of 150 volts amplitude having the same duration as the sweep.

**DELAYED TRIGGER AND SWEEP MAGNIFIER POSITION**—Potentiometer controlling the bias on V101. When the sweep sawtooth reaches this amplitude, the magnified sweep starts. If the MAGNIFIER OUT-IN switch is set to IN, the magnified sweep replaces the regular sweep.

**MAGNIFIER IN-OUT**—Switch connecting sweep amplifier to either normal-or magnified-sweep generator.

**SWEEP TIME/CM**—Potentiometer controlling charging voltage for sweep generators and therefore controlling sweep rate. Controls both normal and magnified sweeps.

**EXT. SWEEP ATTEN.**—Potentiometer controlling the fraction of the voltage applied to EXT. SWEEP INPUT binding post which will reach the grid of the sweep amplifiers when the SWEEP RANGE switch is set in the EXT. position.

**HOR. POSITION**—Potentiometer controlling the bias applied to the grid of one sweep amplifier tube and thereby the horizontal position of the image.



**EXT. SWEEP IN**—Binding post connecting to sweep amplifier via EXT. SWEEP ATTEN. when SWEEP RANGE switch is in EXT. position (100-k input impedance).

**DELAYED TRIGGER**—Binding post providing 75 v positive step at any point on the normal sweep as selected by the DELAYED TRIGGER AND SWEEP MAGNIFIER POSITION control. 15 ma maximum output current.

**SWEEP RANGE**—Gang switch selecting appropriate capacitors and resistors in sweep generator for the various sweep ranges. In the EXT. position, the sweep generator is disconnected and provision is made to feed sweep signals from EXT. SWEEP in binding post.

**SWEEP STABILITY**—Variable resistor controlling bias on grid 3 of the sweep generator tube V112. This bias determines whether the sweep will operate recurrently or must be triggered.

**POWER**—On-off switch in the ac line voltage supply to the oscilloscope.

**TRIGGER AMPL.**—Potentiometer controlling the bias on the trigger amplifier V110, thereby determining the size of the trigger pulse required to trigger the sweep generator.

**TRIGGER SELECTOR TRIGGER INPUT**—  
Switch determining source and polarity

of trigger voltage. Binding post connecting external trigger sources to +EXT. and -EXT. position of TRIGGER SELECTOR switch.

**TIME MARKER IN**—Connector on back of oscilloscope to permit introduction of time markers via an isolating amplifier, V13.

**NOTE:**

The following three screwdriver controls are accessible through the front panels of instruments SN1977 and above. Below this SN, access is provided through the right side of the cabinet.

**C.F. ADJ.**—Potentiometer R51 located in cathode circuit of V5 and V6. Shifts relative operating points of these tubes so that a change in AMPL. ATTEN. setting will not affect the positioning.

**.05-.15 BAL.**—Potentiometer R13 connected between the cathodes of V3 and V4. This control will alter the operating points of these tubes as required to balance this stage in .05-.15 position of VERT. DEF. SENSITIVITY.

**DIFF. BAL.**—Potentiometer located in cathode circuit of V1 and V2. Shifts relative operating points of these tubes to provide a fine adjustment for equalizing A and B input gains for use when the INPUT switch is in the A-B position.

## OPERATING INSTRUCTIONS

The Type 512 may be operated in any normal indoor location, or in the open if protected from moisture. If the instrument has been exposed to dampness, it should be left in a warm room until thoroughly dry before being placed in operation.

To prevent excessive interior temperatures, it is important to allow adequate ventilation for the oscilloscope. Several inches clearance should be provided at the side, back and top of the case.

If the Type 512 is used continuously for the same application, and only one setting of the controls is required, it is advisable to check the instrument periodically at all control settings to be sure it is in normal operating condition. For example, if only direct connection to the vertical deflection plates of the crt is used, a defect in the vertical amplifier might not become evident. Operation of the controls also helps to prevent accumulation of dirt and tarnish on their contacts.

Although the components are well supported and the adjustments are very stable in setting to allow for portable operation, the Type 512 should not be subjected to excessive vibration or rough handling.

To place the Type 512 in operation for the first time, the following procedure is suggested:

1. Connect to a source of 60 cycle, 117 v power (or 234 v if transformer connections are changed as directed on page 24).
2. Set controls as indicated below:

VERT. AMPL. ATTEN.	Clockwise
VERT. DEF. SENS.	5-1.5
VERT. POSITION	Index vertical
AC-DC	DC
VERTICAL INPUT	+CAL
FOCUS	Index vertical
INTENSITY	Counterclockwise
ASTIGMATISM	Counterclockwise
BLANKING	Clockwise
CAL. RANGE	15
CAL. VOLTAGE	0
MAGNIFIER OUT-IN	Out
SWEEP TIME/CM	2
HOR. POSITION	Clockwise
SWEEP RANGE	1-3 Milliseconds
SWEEP STABILITY	Counterclockwise
TRIGGER AMPL.	Counterclockwise
TRIGGER SEL.	+ Int.
3. Turn POWER switch to ON and wait about 60 seconds.
4. Advance INTENSITY control until a spot is seen.
5. Adjust VERT. POSITION, HOR. POSITION, ASTIGMATISM, and FOCUS until a sharply focused spot is obtained at the left center of the screen.
6. Advance the SWEEP STABILITY control until a sweep appears, then turn it back just under this point.
7. Set the CAL. VOLTAGE control to 5 and a vertical line about 3 cm high should appear.

**CAUTION--DO NOT ALLOW THIS SPOT TO BE EXCESSIVELY BRIGHT OR REMAIN FOR LONG IN ONE POSITION.**



8. Advance the TRIGGER AMPL. control until a stable image of the calibrating signal appears.
9. Retard BLANKING control until the return trace is removed.

The oscilloscope is now displaying the square wave calibrating signal. To observe other wave-shapes, connect them directly, or through a probe, to the INPUT A connector, turn VERTICAL INPUT switch to A, select the appropriate

## HORIZONTAL DEFLECTION SYSTEM

The sweep circuit of the Type 512 employs a phantastron sweep generator which is much more flexible and accurate than the gas tube type usually employed in portable oscilloscopes. By one simple adjustment, the sweep can be made to run either triggered or recurrently as desired.

In a recurrent sawtooth sweep as generated by a gas tube or similar device, the synchronization takes place at the end of the sweep. The sync impulse causes the beam to return to the left side of the tube where it immediately starts another sweep. Thus, the sweep time must be a multiple of the signal period, or expressed another way, the sweep frequency an integral fraction of the signal frequency.

In a triggered sweep circuit, each sweep is started independently of the preceding sweep by a trigger or synchronizing impulse. When no trigger is being received, the beam remains at the left side of the screen. When the trigger arrives, the beam goes linearly to the right for a time, in this case determined by the phantastron sweep generator. At the end of its sweep, it returns to the left side again to await another trigger. It is this variable waiting period which makes the synchronization so easy since the sweep time is now independent of the signal period.

sweep time, vertical deflection sensitivity, etc.

Differential input, high frequency operation, etc., are explained under "Vertical Deflection System":

**CAUTION—ANY TIME THE TYPE 512 IS SWITCHED OFF IT IS ADVISABLE TO WAIT ABOUT 30 SECONDS BEFORE SWITCHING THE POWER BACK ON. THIS PRECAUTION WILL AVOID "HOT SURGE" CURRENTS WHICH MIGHT BLOW THE FUSE.**

### Adjustment of Sweep Stability

The SWEEP STABILITY control varies the bias on the suppressor (grid 3) of V112 and therefore determines whether the sweep will oscillate recurrently or wait for a trigger impulse. The correct setting of the SWEEP STABILITY control depends somewhat on the particular sweep speed in use, but satisfactory operation can be obtained for all but the smallest triggers by a single setting a little below the critical point.

### Function of Trigger Selector

This control selects the trigger impulse to be used from three sources, the line frequency (60 cycles), the vertical amplifier +INT. AND -INT.), or the TRIGGER INPUT binding post. Two positions are available for both the INT. and EXT. sources. When using those marked +, the sweep starts at the rising portion of the trigger impulse. The - positions start the sweep on the falling portion. For satisfactory operation in the EXT. positions, a trigger of from 0.15 v to 50 v sine or square wave or pulses of 0.15 v to 15 v should be provided in instruments SN1985 and up. Below SN 1985 minimum trigger amplitude should be 0.5 V. Excessively large triggers should be reduced by an external attenuator.

### Adjustment of Trigger Ampl.

The TRIGGER AMPL. control adjusts the bias in the trigger amplifier and therefore the amplitude of the impulse which reaches the sweep generator. After the SWEEP STABILITY is set as described previously, and the TRIGGER SEL. switch set to the correct position, advance the TRIGGER AMPL. control until a stable image is obtained. When the trigger source is a slowly changing wave such as a sine wave or sawtooth adjustment of the TRIGGER AMPL. setting will change the phase of the signal relative to the start of the sweep.

In general, it is desirable to use the minimum TRIGGER AMPL. setting required to insure a stable image.

If poor synchronizing is experienced when the Type 512 is used to observe repetitive signals containing erratic peak voltages, such as produced by vibrating contacts, it may be possible to form a stabilized trigger signal by the use of auxiliary limiting and differentiating circuits. The TRIGGER SEL. switch should be set to the proper EXT. polarity, and connection made to the TRIGGER INPUT.

### Adjustment of Sweep Rate

The combination of the SWEEP RANGE and SWEEP TIME/CM controls allows the operator to vary the sweep rate from 0.3 sec/cm to 3 microseconds/cm. The rate in time/cm may be read directly from the appropriate scale on the SWEEP TIME/CM dial. Provision has been made to correct this calibration should the cathode ray tube or sweep amplifier tube be replaced. Procedure for this adjustment will be found on pages 27 and 28.

### Recurrent Sweep

In case it is desirable to have a sweep without using any sort of trigger, merely advance the SWEEP STABILITY control until a stable sweep is obtained. This is the conventional recurrent sweep as used in most oscilloscopes.

### Single Sweep

The triggered sweep circuit used in the Type 512 inherently provides for single sweep operation. The beam is blanked out until the trigger simultaneously turns it on and starts the sweep. This trigger may be a suitable pulse, or if a mechanical contactor is to be used it is merely necessary to set the TRIGGER SEL. switch to -EXT. and ground the TRIGGER INPUT binding post by means of the contactor. When a mechanical contactor is employed, it may prove desirable to shunt the contactor with a suitable capacitor so that a definite time must elapse before a second sweep may occur. This eliminates the possibility of unwanted sweeps caused by bouncing contacts.

### Blanking

A control is provided on the Type 512 to vary the amplitude of the blanking voltage applied to the crt grid at times when the sweep is not running. In many single-sweep applications it is desirable to know the position of the spot before the sweep starts. This may be accomplished by adjusting the BLANKING control until a spot of the desired intensity is obtained.

### Ext. Sweep Input

Provision has been made for the connection of external sweep generators to the Type 512. This might be a sine wave oscillator for frequency comparison, the sweep obtained from a "frequency sweep" signal generator, or a sweep generator designed for some particular purpose. The EXT. SWEEP INPUT binding post is connected to the horizontal deflection plates via the EXT. SWEEP ATTEN. and a one-stage push-pull amplifier. The entire system is dc coupled permitting the use of very slow sweeps. With the EXT. SWEEP ATTEN. fully clockwise, the deflection sensitivity is approximately 1.0 volt per cm dc or peak to peak ac, for instruments using the 5ABP7 CRT, or 1.5 v/cm with the 5CP7 CRT.

### Sweep Magnifier

Frequently it is desirable to examine in



some detail a portion of the waveshape under observation, for instance the rate of fall of the end of a fairly long pulse. In the Type 512 the Sweep magnifier circuit makes it possible to expand any desired 20% of the sweep to cover the entire tube face. When the MAGNIFIER IN-OUT switch is moved to the IN position, the sweep is delayed for a variable time and then goes at 5 times its normal rate. The operating procedure is to turn the MAGNIFIER IN-OUT switch to IN. Now turn the DELAYED TRIGGER AND SWEEP MAGNIFIER POSITION knob completely clockwise and then decrease it until the desired signal moves in from the left to the center of the tube face. When the SWEEP RANGE switch is in the fastest position, the magnified sweep is less accurate and linear than in the other positions because of the shunting effect of circuit capacities.

#### Delayed Trigger

The DELAYED TRIGGER output is a + gate of approximately 75 volts amplitude, starting at any desired time during the period of

the sweep, as determined by the setting of the DELAYED TRIGGER and SWEEP MAGNIFIER POSITION control. The start is coincident with the start of the magnified sweep when the SWEEP MAGNIFIER is in use. Should a spike be desired rather than the positive step an external differentiating circuit of any desired time constant may be used.

#### Sweep Output

The SWEEP OUTPUT binding post makes available the waveshape appearing on the plate of the sweep generator tube. V113 is used as a cathode follower to isolate the sweep generator from whatever is connected to the SWEEP OUTPUT post. The amplitude is approximately 100 v peak to peak.

#### Gate Output

A positive square wave of the same duration as the sweep and 150 volts amplitude is available for external use. Isolation is provided by one section of V106.

### VERTICAL DEFLECTION SYSTEM

The Type 512 is equipped with two input probes which fit the UHF Input Connectors directly and two Binding Post Adapters which convert the UHF connectors to binding posts. A ground lead to the equipment under observation must be provided and often an earth ground is desirable. Connect one of the probes or a Binding Post Adapter and a single lead to INPUT A. The VERTICAL INPUT switch should be in position A. When reduced loading on the circuit under test is desired, one of the Input Probes should be used.

**CAUTION—THE PEAK POTENTIAL APPLIED TO THE PROBES SHOULD NOT EXCEED 600 VOLTS.**

However, since the Probe introduces an attenuation of 10X, it will be advantageous to employ a common shielded lead (no attenuation) instead when dealing with very low level signals,

provided the additional circuit loading is permissible. If balanced (push-pull) input is desired, the VERTICAL INPUT switch should be set at A-B and connections be made to both INPUT A and INPUT B.

#### Vertical Amplifier

In order to reconcile the inherent conflicting problems of maximum bandwidth and high dc gain with good stability, a switching system is incorporated which automatically removes the two stage preamp whenever sufficient sensitivity can be attained without it. This same switch (VERT. DEF. SENSITIVITY) inserts appropriate rc compensated attenuators in the circuit so that eight steps (approximately 10db each of sensitivity are available, ranging from 5 mv to 50 v per cm.) Sensitivity is reduced by a factor of 10 when the standard probe is used. When the preamp is not used, i.e., for sensitivity

below 0.15 v/cm the bandwidth is 2 mc. For higher sensitivities, it is necessary to pay more attention to grid current, stability, hum, microphonics, etc., and suitable high conductance tubes are not available for the first preamp stage. This reduces the possible bandwidth for reasonable gain so that only a 1-mc pass band is obtained. To provide continuously variable control of gain between the steps on the VERT. DEF. SENSITIVITY switch, twin potentiometers are provided in the cathode-follower stage.

If the Type 512 is to be employed in an application requiring both high gain and direct coupling of the vertical amplifier, a twenty-to thirty-minute warm-up period to stabilize tube characteristics should be provided.

#### Differential Amplifier

In many applications, the desired signal is superimposed on an undesirable signal such as line frequency hum, etc. The balanced "push-pull" or "differential" amplifier in the Type 512 makes it possible in many cases to greatly increase the ratio of desired to undesired signals. To accomplish this, the VERTICAL INPUT switch is placed in the A-B position and both inputs A and B are used. The image on the CRT will be the difference in potential between the A and B inputs. If a connection can be made with one input having both signals and the other having only the undesired signal, the difference between them, i.e., the desired signal will appear. To compensate for variation in tubes, etc., a screwdriver control, labeled DIFF. BAL., is provided (see page 25).

#### Standardized Input Impedance

By means of trimming capacitors and accurate (1%) resistors the input impedance of both sides of the amplifier, at any setting of the VERT. DEF. SENSITIVITY switch is standardized at 1 meg. shunted by 45 mmfd. This makes the probes interchangeable on the A and B inputs and between various instruments.

#### Direct Connection to Deflection Plates

Direct connection to the crt deflection plates is made by means of the banana jacks on the access panel. This panel is accessible through

an opening in the left side of the case. By removing the jumpers the internal circuits may be disconnected. The terminal marked Y1 is the top plate and the one marked X2 is the right plate. Deflection sensitivity is approximately 13 v/cm on the vertical plates and 18 v/cm on the horizontal plates for the type 5ABP7 crt, or 25 v/cm vertical and 32 v/cm horizontal for the type 5CP7.

#### High Frequency Operation

The Type 512 may be used to observe the envelope shape of radio frequency voltages above the frequency capabilities of the vertical amplifier by means of a connection via the side access panel. Since the deflection plates are operated at the plate voltage of the vertical amplifier output stage (+150), a series coupling capacitor should be employed. The jumpers from Y1 and Y2 to the vertical amplifier output should be replaced with 1 megohm resistors, to provide vertical positioning voltage. Unless balanced input is desired, the unused deflection plate should be by-passed to ground. Input to Y1 will provide upward deflection for a positive voltage.

#### Time-Marker Input

Time markers, etc., may be introduced to the vertical amplifier via the overbiased isolating amplifier V13, without interaction with the waveform under observation. This connection is at the rear of the Type 512. A minimum time marker amplitude of about 8 volts is required.

#### Calibration

The cathode ray oscilloscope provides the only means for making many types of measurement on non-sinusoidal wave shapes, usually qualitative rather than quantitative in nature. To aid in amplitude measurement, the Type 512 incorporates a square-wave calibrator. By means of a step attenuator and calibrated potentiometer the amplitude of this square wave may be set to any desired value from 1 mv to 50 volts, peak to peak. Ten ranges are available by means of the step attenuator and the amplitude of any portion of the signal under observation may thus be measured to an accuracy of plus or minus 5%.





If direct coupling is being used (SW2 in DC position) the calibrating voltage will produce an upward deflection with the VERTICAL INPUT switch set at +CAL. and a downward deflection when -CAL. is used. Thus, the amplitude of any portion of the signal under observation may be measured with respect to the zero potential (ground) point by moving the VERTICAL INPUT switch to the desired CAL. polarity and adjusting the CAL. RANGE and CAL. VOLTAGE until the variable portion of the calibrating waveform coincides with the deflection produced by the signal. The peak amplitude is then read directly in volts from the CAL. RANGE and CAL. VOLTAGE control.

**CAUTION—IF THE INPUT PROBE (ATTEN. 10X) IS USED, THE SIGNAL AMPLITUDE IS EQUAL TO TEN TIMES THE CALIBRATING VOLTAGE.**

It is not necessary to change the sweep time or to synchronize the calibrating signal, as two horizontal lines are produced when the sweep is not in sync with the calibrating voltage.

If the AC position of SW2 is used, the Calibrating Voltage produces equal deflection in both directions in either the +CAL. or -CAL. positions. In this case, the same procedure is followed, except that the calibrating voltage is adjusted to coincide in both amplitude and vertical position to the signal being measured.

**CAUTION—TO PROVIDE MAXIMUM ACCURACY, A REASONABLY LARGE DEFLECTION SHOULD BE USED, BUT TO PREVENT POSSIBLE ERROR DUE**

**TO OVERLOADING OF THE VERTICAL AMPLIFIER, THE DEFLECTION SHOULD NOT EXCEED THE RULED PORTION OF THE GRATICULE (PLUS OR MINUS 3 cm.) DURING CALIBRATION.**

The calibrating voltage is available externally at the CAL. OUTPUT binding post when the CAL. toggle switch is in either the NORM. or EXT. position if the VERTICAL INPUT switch is set at +CAL. or -CAL. To obtain CAL. OUTPUT voltage with the VERTICAL INPUT in the A or A-B position, the CAL. switch must be set at EXT. It is convenient to use this connection in determining the signal amplitude when an attenuating probe is used, as it is then unnecessary to make allowance for the attenuation factor of the probe. The CAL. OUTPUT may be used during adjustment of the Type 512's vertical amplifier (see pages 24-26) and also provides a square wave of known amplitude suitable for testing other equipment.

#### Intensity Modulation

If desired, signals may be impressed on the cathode of the cathode-ray tube thus modulating its brightness. The CRT CATHODE binding post is connected to the cathode via a .1 mfd. capacitor. The cathode resistor is 100 k. Since the time constant is only .01 sec. long, square pulses cannot be transmitted without some loss of shape. Its primary purpose is to transmit short pulses such as time-markers, etc.

## CIRCUIT DESCRIPTION

### CATHODE RAY TUBE CIRCUITS

The Type 512 employs a 5CPA (SN 101-2525) or 5ABP (SN 2526 and up) cathode ray tube. These tubes have 5-inch fluorescent screens and utilize electrostatic focus and deflection. A post accelerating electrode (intensifier) provides increased spot intensity. The total accelerating potential of about 3000 volts produces a sharp bright image easily visible in normal room light.

The various negative voltages necessary to operate the cathode ray tube are obtained from a voltage divider network across the -1500-volt supply. The components of this network and the blanking bias rectifier circuit are mounted on a small chassis at the base of the tube. Potentiometer R351 (R308 below SN 2147) labeled INTENSITY, permits adjustment of the grid bias, which controls the beam current and thus the image brightness. Bypassing is provided by C304 and C257 (C205 below SN2147—located in the power supply). R352, (R307 below SN 2147) in series with the cathode, limits the maximum beam current to a desirable value and allows external brightening or blanking impulses to be introduced via the CRT CATHODE binding post and the .1 $\mu$ f 2000 volt capacitor, C303. In order to bring the electron

beam into sharp focus at the screen, the potential of the first anode is made adjustable by means of the FOCUS potentiometer, R305. Adjustment of the second anode potential is provided by the ASTIGMATISM potentiometer, R303, permitting good focus to be obtained on both horizontal and vertical lines simultaneously. R303 is connected between the +250 volt and -150-volt supplies, and has adequate range to provide proper focusing when the crt deflection plates are operated at either their normal average potential of +150 volts, or at ground average potential.

Each of the four deflection plates is connected via a short, low capacitance lead to a banana jack on the side access panel. This feature permits convenient direct connection for high-frequency observation, etc. See Operating Instructions.

The accelerating electrode is connected directly to the +1500-volt circuit of the power supply. Edge lighting of the plastic graticule is provided by two Mazda No. 47 lamps, and the intensity of the lines is varied by means of the SCALE ILLUM. control, R302.

### HORIZONTAL DEFLECTION SYSTEM

The sweep chassis, located in the lower front portion of the Type 512, contains the circuits which deflect the electron beam horizontally across the crt screen at a uniform rate. The sweep may be operated either recurrently (sawtooth); or triggered (driven) by the signal under observation, an external impulse, or the 60-cycle line. Other circuits apply a blanking bias to the crt grid during the flyback and waiting periods. Gate, sweep sawtooth, and delayed trigger waveforms are made available at front panel binding posts. A square-wave calibrator, operating at approximately 1 kc. provides an accurate means of measuring signal amplitudes and a convenient signal source for

many circuit adjustments of the Type 512. The calibrator circuits are described under "Vertical Deflection System".

#### Trigger Circuits

With the SWEEP STABILITY control adjusted for triggered sweep operation, each sweep is initiated independently of the preceding sweep by a trigger or synchronizing impulse. The function of the trigger circuits is to select the trigger signal from the desired source, amplify or attenuate it as required, and apply it with suitable polarity to the sweep generator.



## Trigger Selector

The TRIGGER SEL. switch, SW101, operating in conjunction with the cathode coupled amplifier stage, V108 and V109, selects the source of trigger signal and reverses its polarity if necessary. The trigger impulse or signal under observation is applied to the grid of V108 and appears at the plate amplified and opposite in polarity. Due to the common cathode resistor, R139, and the grounded grid of V109, an amplitude signal of the original polarity appears at the plate of V109. A positive impulse is required at the grid of V110 to produce the proper trigger polarity for the sweep generator. Therefore, the TRIGGER SEL. switch is connected so that on the +EXT. setting the amplified trigger signal is taken from the plate of V109, thus maintaining its original polarity. In the -EXT. position, polarity inversion is required and connection is made to the plate of V108.

The internal trigger signal is taken from a divider, R71 and R72, in the plate circuit of the vertical amplifier output stage. Since the polarity of this signal is opposite that of the signal applied to the vertical amplifier INPUT A, it is necessary to connect to the plate of V108 for +INT. and to the plate of V109 for -INT. positions of the TRIGGER SEL. in order to obtain correct trigger polarity.

In the fifth position of SW101, the trigger amplifier input is connected to the 6.3-volt ac heater supply, to permit synchronization with the line frequency.

## Trigger Amplitude Control

The extended bandwidth and versatility of the Type 512 require utmost flexibility in the trigger circuits to assure stable images of the wide variety of waveforms which may be encountered. The desired control is achieved by an amplifier stage with V110. The TRIGGER AMPL. potentiometer, R143, permits adjustment of the bias of V110 from the point at which plate-current cutoff occurs (about 7 volts) to about 80 volts. This range of control together with the high overall gain of the trigger circuits provides suitable trigger impulses from external inputs of 0.15 to 15 v, (below SN 1985, 0.5 to 15 v)

and from crt deflections of 5 mm or greater when the internal settings are used. The special taper of R143 makes adjustment very smooth in operation. Since the plate current of V110 remains cut off (until a positive signal is applied to the grid) the grid of the limiting cathode-follower section of the 6J6 tube, V111, is held at constant potential of approximately 150 volts by the divider R146, R147 (and R148 below SN1985). The cathode of V111 is maintained at a similar value. This potential is divided between R150 and R151, with 2.5 volts appearing across the R151.

The amplified trigger impulse, of negative polarity, which appears at the plate of V110, is applied to the grid of the cathode follower. The cathode falls with the grid, but because of the long time constant of R150 and the charged capacitor, C113, the fall is limited to 2.5 volts. This value is sufficient to properly trigger the sweep, but small enough to prevent disturbing the sweep linearity. The peak of the trigger impulse is clipped by this limiting action of the cathode follower, and the base level is determined by the bias on V110, which the TRIGGER AMPL. control establishes. Therefore, when the trigger source is a sine-wave, sawtooth or other slowly changing waveform, the phase of the observed image will vary relative to the start of the sweep with changes in trigger signal amplitude or setting of the TRIGGER AMPL. control.

## Trigger Coupling Diode

During the period when no signal is being received from the trigger amplifier, the plate of the sweep generator, V112, is held at about +150 volts by the diode connected section of V111. When a trigger impulse causes the cathode of V111 to fall to the potential of C113, an equal fall occurs at the diode and sweep generator plates, thus initiating the sweep cycle. The diode is used in preference to a coupling capacitor because it disconnects the sweep generator from influence of the trigger amplifier as soon as the sweep is underway. This occurs because the plate of V112 falls linearly until the sweep cycle is completed, holding the diode plate negative with respect to its cathode, and thus prevents conduction of additional trigger impulses until the sweep generator is ready to begin another cycle.

## Phantastron Sweep Generator

The sweep generator circuit, employing a screen coupled phantastron\*, V112, and associated charging cathode follower, 1/2 of V113, provides a linear sawtooth voltage for deflection of the crt beam, and a gating voltage for control of the crt blanking bias oscillator. The excellent linearity and stability of this circuit, matched by accurately calibrated timing controls, virtually obviates the need for time markers.

This flexible circuit is inherently capable of producing a sawtooth voltage of large amplitude, with excellent linearity. A single SWEEP STABILITY control, R152, provides for either triggered or recurrent operation of the sweep by adjusting the suppressor bias of V112.

## Triggered Sweep

With the SWEEP STABILITY control set for triggered operation, sufficient suppressor bias is applied to cause plate-current cutoff and the plate of V112 is held at about +150 volts, as described under "Trigger Circuits". Since the cathode is grounded, the grid is held slightly positive by the current flowing in the timing resistor R165 (or R164 and R165), and the screen is at a low potential as it is taking the current which would normally flow to the plate.

When the negative trigger impulse is received, causing the plate to fall, the grid and consequently the cathode of the charging cathode follower section of V113 fall correspondingly. Since the timing capacitor, C117 to C121, which is charged to 150 volts, cannot discharge immediately, this impulse is coupled to the grid as a negative bias, thus greatly reducing the screen current. This causes the screen voltage to rise. As the suppressor voltage is determined by the voltage appearing across the divider R152, R153 and R154, it is simultaneously raised and plate current begins to flow. C114 compensates for

\*For a discussion of phantastron circuits, see Radiation Laboratory Series, Vol. 19, pp. 195-204.

shunt capacitance, maintaining the fast rise necessary at high sweep speeds. Since the cathode current in a pentode is fairly constant, any increase in plate current decreases the screen current. This action is regenerative and causes the plate current to increase rapidly. The resultant voltage drop is transferred to the grid via the cathode-follower section of V113 and timing capacitor, (C117-C121). With the circuit constants used in the Type 512, this initial fall is limited to about five volts by the feedback between plate and grid, before the phantastron action begins. When the grid is carried below cathode potential, two effects take place. First the total plate and screen current is reduced to a very small value. Second, the grid no longer takes the current flowing in the timing resistor R165 (or R164 plus R165). This current now can flow only in the timing capacitor. As one end of the timing resistor is held constant by the SWEEP TIME/CM control, R161, the voltage drop across it and consequently the discharge current of the timing capacitor will depend on the grid voltage of V112. Any tendency for the grid to change causes a corresponding plate current change and is counteracted by an opposing voltage coupled back to the grid from the plate via the cathode follower and timing capacitor. Thus a state of equilibrium is maintained, holding the grid potential nearly constant. As the timing capacitor discharges, the grid rises slightly, permitting the increased plate current necessary to cause the phantastron plate and cathode follower cathode to fall correspondingly. Since the grid needs to change less than a volt to cause the entire plate swing, the voltage across the timing resistor and therefore the current through it remains almost constant during the sweep. This constant current, discharging the timing capacitor, causes a linear change in the voltage across it. Since the grid end of the timing capacitor changes very little, the other end falls in a linear sawtooth. To get a quantitative idea of the linearity, consider the following typical constants. Plate load 500K, charging voltage 100, transconductance of tube 2 ma/v. For a 100-volt plate swing 0.2 ma discharging current would be needed. This requires 0.1 v grid change. The initial discharging current will therefore be only 0.1% greater than the terminal discharging current.



When the plate reaches such a low voltage that it can no longer hold the grid down, the total current begins to rise. Since the plate can take no more current, the increased current goes to the screen which begins to fall. The screen-suppressor coupling carries the suppressor down, thus decreasing the plate component of the total current. This regenerative action rapidly cuts the plate current off because of the suppressor bias, and leaves the circuit in its initial condition, i.e., grid taking the charging current (formerly flowing in the timing capacitor), screen at a low voltage and plate held by the trigger coupling diode.

#### Charging Cathode Follower

The purpose of the charging cathode follower is to reduce the time required to recharge the timing capacitor. If the timing capacitor were connected between the grid and plate of V112, the sweep portion of the cycle would remain unchanged, but the time necessary to recharge the timing capacitor would be much longer since it would charge through the 470-k plate resistor, R157. By connecting the cathode follower (one section of V113) between the plate and the timing capacitor, very rapid recharging is possible. The plate of V112 rises rapidly since it has only the tube capacities in shunt with it. When the plate rises, it carries the grid up with it and consequently the cathode of V113. The other side of the timing capacitor is held near ground by the diode action of the phantastron grid. Thus the timing capacitor charging current is supplied by V113, and may be large due to the low circuit resistance. This feature reduces the sweep flyback time to a minimum.

#### Recurrent Sweep

Recurrent (sawtooth) operation is obtained by advancing the SWEEP STABILITY control, R152, until the negative suppressor bias of V112 is reduced sufficiently to permit plate current to flow at the beginning of the cycle. With this setting, a new cycle is started immediately upon completion of the previous one, as a trigger impulse is not required to cause the initial plate fall.

#### Sweep Timing

Accurate adjustment of sweep time is made possible by two calibrated front-panel controls. The 11-position SWEEP RANGE switch, SW102, selects one of the timing capacitors. Each capacitor is used for two ranges. Another section of SW102 short circuits a portion (R164) of the precision timing resistor in alternate ranges. Thus, the complete sweep time range of 3  $\mu$ sec/cm to .3 sec/cm is covered, in two steps per decade, with ten switch positions. The eleventh position provides for connecting an external signal to the sweep amplifier. Precise continuously variable control for each step of the SWEEP RANGE switch is provided by the calibrated SWEEP TIME/CM, potentiometer, R161. This control adjusts the voltage to which the timing resistor is returned, thereby controlling the discharge rate of the timing capacitor.

Good tracking of the SWEEP TIME/CM dial is made possible by the screwdriver controls, SWEEP TIME A and SWEEP TIME B, which permit accurate adjustments of the voltage at both ends of R161. R156 and R158 compensate for the change in timing resistance as the SWEEP RANGE switch is rotated, and permit the same setting of the SWEEP STABILITY control at all ranges.

#### Sweep Output Cathode Follower

The other section of V113 is employed as a cathode follower to isolate the SWEEP OUTPUT binding post from the sweep generator, providing a sawtooth waveform of about 100 volts amplitude at the front panel.

#### Sweep Amplifier

The sweep amplifier provides the balanced (push-pull) waveform of about 350 volts amplitude required to deflect the beam horizontally across the crt screen. The balanced output maintains a constant average deflection plate potential over the entire sweep and thus prevents defocusing of the spot. This amplifier employs

V114 in a cathode-coupled\* circuit. With SW102 in any of the first ten positions, i.e., when using the internal sweep generator, the phantastron plate waveform is connected to the control grid of V114B via the divider, R166 and R167. This divider is necessary because the 150-volt sweep-generator waveform must be attenuated to prevent overdriving the sweep amplifier. Attenuation is employed, rather than a reduction of amplifier gain, so that maximum sensitivity is available when the SWEEP RANGE switch is in the eleventh or EXT. position.

In the EXT. position, the sweep amplifier grid connections are reversed, so that a positive-slope sawtooth applied to the EXT. SWEEP INPUT causes a left to right deflection. Amplitude is controlled by the EXT. SWEEP ATTEN. potentiometer, R171. In either case, horizontal positioning of the beam is accomplished by varying the bias of the opposite grid, thereby changing the plate current and consequently the plate voltage of one section of V114 with respect to the other. The range of the HOR. POSITION control, R169, is set by the dividers R169.1 and R170 on the positive end, and R169.2 and R169.3 on the negative end.

To obtain good focus on the cathode-ray tube, it is necessary for the second anode and both pairs of deflection plates to operate at approximately the same average potential. Since the 150-volt average potential of the vertical deflection plates is determined by the vertical amplifier output stage, the 250-volt average at the sweep amplifier plates must be reduced to this value. This is accomplished by two Type NE-2 neon lamps in series with each plate of V114 and associated crt deflection plate. As the neon lamps maintain a constant potential of about 55 volts each, the sweep sawtooth (or other waveform) at the plates of V114 appears unchanged at the deflection plates except moved down 110 volts. A steady current of about 250 microamperes, supplied from the negative high-voltage power supply via R179 and R180, keeps the neon lamps ionized regardless of changes in the sweep amplifier plate potentials. The stabilizing resistors, R177.1 and R178.1,

\*See Puckle "Times Bases", pp. 119-125, for a discussion of cathode-coupled amplifiers.

eliminate any tendency toward spurious oscillation. The impedance of the neon lamps is rather high at the frequencies involved in the faster sweeps, so a low-impedance path is provided by C123 and C124.

Any change in gain of the sweep amplifier, such as might be caused by aging or replacement of V114, will be evidenced by error in the indicated sweep time. Therefore, in order to realize the full benefits of the accurate timing controls and stable adjustments of the sweep generator, the sweep amplifier gain is made variable. This is accomplished by means of degeneration in the cathode circuit, which may be varied by adjusting R176. See the Adjustment Section for details.

#### Delayed Trigger and Sweep Magnifier

The delayed trigger and sweep-magnifier-gate waveforms are derived from the sawtooth output of the phantastron sweep generator. Since the magnified-sweep generator employs its own time constants, and the normal sweep generator functions only as a gate, the magnified sweep waveform is independent of the preceding circuits. This design results in a magnified sweep having excellent linearity and accurate timing.

#### Delay Selector

This circuit, utilizing a cathode-coupled dual triode, V101, determines the point on the normal sweep at which the delayed trigger and start of the magnified sweep occur. The 150-volt sweep generator sawtooth is applied to the control grid of V101A and a similar waveform appears at the cathode across R101. The potential of the control grid of V101B is determined by the divider R103, R104 and R105, and may be varied by adjusting the DELAYED TRIGGER AND SWEEP MAGNIFIER POSITION control, R104. C101 holds the grid constant during the sweep cycle. Since the large amplitude of the cathode waveform causes either plate current saturation or cutoff (or both, depending on the setting of R104) only a small portion of the sawtooth waveform appears in amplified form at the plate of the output section. The range of R104 is sufficient to permit selection of any desired portion of the cathode waveform, thus providing a continuously variable delay.



## Shaper

The waveform at the selector plate requires further limiting and amplifying to provide the steep wavefront required for gating the magnified-sweep generator and triggering associated equipment. This is accomplished by the shaper circuit with V102. The compensated divider, R106, C102 and R107, provides direct coupling to the grid, preserving the waveform at both the extreme high and low sweep speeds. The amplified and inverted signal which appears at the shaper plate has a rise time of approximately 1% of the 10-centimeter sweep duration. (The rise is somewhat slower at the highest sweep speeds.)

## Delayed-Trigger Cathode Follower

One section of V104 is employed as a cathode follower to provide a relatively low impedance for the delayed-trigger output. This cathode follower also serves to isolate equipment connected to the DELAYED TRIGGER binding post from the magnified-sweep circuits.

## Magnified-Sweep Generator

The magnified sweep is generated by an externally gated Miller run-down circuit which is similar in operation to the phantastron circuit employed in the normal-sweep generator. The same group of timing capacitors is used, except for the two highest ranges, and these capacitors are selected by the SWEEP RANGE switch. While SW102D and SW102G insert the desired timing capacitor into the phantastron circuit, SW102E and SW102F simultaneously select the next smaller capacitor for the magnified sweep. SW102B selects corresponding timing resistors, R115 and R116, of 1% tolerance, thus accurately maintaining the magnified sweep time at 20% of the normal sweep time.

At the beginning of the normal sweep, the plate voltage of the shaper, V102, is held at a low value because of the large plate current. This voltage, applied to the compensated divider, R110, C104 and R111, holds the suppressor of V103 at negative potential, since the divider is returned to the -150-volt supply. The negative suppressor bias prevents plate current flow and the plate voltage is determined by the cathode-follower voltage regulator, V105. The grid is near ground

potential and a large screen current flow keeps the screen voltage at a low value. The timing capacitor is charged.

After a delay, determined by the setting of the DELAYED TRIGGER AND SWEEP MAGNIFIER POSITION control, the amplified portion of the normal-sweep sawtooth from the delay selector appears at the grid of V102, causing rapid plate-current cutoff. This causes the plate voltage to rise quickly toward the +250-volt supply, and results in a slightly positive suppressor bias on V103. The plate current flow which now occurs in V103 causes the plate voltage to fall rapidly, carrying with it the grid and consequently the cathode of V104A. As the timing capacitor cannot discharge immediately, the grid of V103 also falls rapidly. This action continues several volts until the grid approaches the point of cathode current cutoff, and an equilibrium is established, where further fall is counteracted by the reduced plate current it causes.

At this point, the linear run down (described under "Phantastron Sweep Generator") begins and continues until the plate is nearly at ground and the timing capacitor almost discharged. This condition is maintained until the end of the normal sweep, when the positive gate pulse is removed from the suppressor of V103, and the negative bias reapplied. As plate current is now cut off, the plate rapidly returns to its original potential, set by V105, carrying with it the grid and cathode of the charging cathode follower, thus recharging the timing capacitor. Simultaneously the grid and screen return to their original potentials and the circuit now ready to generate another sawtooth waveform when another gate is applied to the suppressor. The sawtooth waveform is taken from the tapped cathode resistor, R117 and R118, in the same manner as the normal sweep. With the MAGNIFIER switch, SW103, in the IN position, the sweep amplifier input is connected to the magnified sweep generator; in the OUT position connection is made to the normal-sweep generator.

## Cathode Follower Voltage Regulator

This circuit, with V105, is similar in operation to the limiting cathode follower described under "Trigger Amplitude Control", but omits the

limiting function. Its purpose is to prevent the magnified-sweep generator plate from rising above a desired potential. This is the value required to make the starting point of the magnified sweep coincident with that of the normal sweep. The voltage of the cathode follower section grid of V105 is set by the divider R123, R124 and R125 and maintains the cathode at a similar value. As the magnified-sweep generator plate is connected to the diode section plate of V105, it cannot rise appreciably above the cathode potential. When the plate of V103 falls during the period of the magnified sweep, the diode plate becomes negative with respect to the cathode, and the cathode follower exercises no further control until the end of the normal sweep cycle. The variable section of the divider, R123, labeled MAG. POS., permits accurate adjustment of the magnified sweep starting position to be made.

## Blanking Oscillator

In addition to the manual INTENSITY control, R351 (R308 below SN 2147) an automatic blanking circuit is employed to cut off the crt beam current during the sweep fly back and waiting periods. Since the waiting period (with spot at the left side of crt and sweep generator awaiting the initiating trigger) may be minutes long when the Type 512 is used for observing aperiodic phenomena or for single sweep operation, it is essential that the blanking bias amplitude be independent of time. That is, the spot should remain completely extinguished regardless of the duration of the waiting period. Control of the blanking is also desirable to permit a dim spot for position reference.

These requirements are satisfied by a gated high-frequency oscillator and rectifier, or carrier circuit.

## VERTICAL DEFLECTION SYSTEM

The vertical deflection system provides the means of attenuating or amplifying input signals so that they present an image of convenient amplitude on the cathode-ray-tube screen. Sig-

The gate voltage is derived from the positive square-wave screen waveform of the phantastron sweep generator. This signal is direct coupled to the blanking gate inverter amplifier (1/2 of V106) grid via the compensated divider R126, C106 and R127. The large grid swing causes both saturation and cut off of plate current, resulting in a very nearly square, inverted plate waveform, which is applied to the suppressor of the blanking oscillator, V107, by way of another divider, R131.1, R131.2 and R131.3.

V107 is employed in a conventional Colpitts oscillator circuit. Link coupling provides a low-impedance connection to the blanking-bias rectifier, V302, and also the necessary insulation from the -1500-volt crt circuit. Both the oscillator and rectifier tuned circuits are made adjustable by means of variable inductors, so that they may be resonated. The rectifier is polarized so that the rectified high-frequency carrier is applied as a negative bias to the crt grid. The BLANKING control, R131.1, permits variation of the oscillator suppressor bias existing during the flyback and waiting periods, thus controlling the amplitude of oscillation and consequently the blanking bias.

## Positive-Gate Generator

The +gate, a 150-volt square wave of the same duration as the sweep, is also derived from the screen waveform of the phantastron sweep generator. A portion of the square negative waveform at the plate of the blanking-gate inverter section of V106 is applied to the grid of the other section and appears, inverted and amplified, at the plate. This circuit provides a relatively low impedance output and isolates any equipment connected to the +GATE binding post from the blanking circuit.

nals may be attenuated 2 times (20 times with probe) or amplified as much as 5,000 times without appreciable distortion. Signal amplitude is easily determined by means of accurate



attenuator and calibrator circuits. Direct banana-jack connections to the cathode-ray tube deflection plates at a side access panel provide a convenient low-capacitance, low-inductance input when it is undesirable to use the vertical amplifier.

### Vertical Amplifier

The balanced push-pull vertical-amplifier circuits of the Type 512 are located on the upper chassis, and consist of a two-stage preamplifier, a step attenuator, a variable attenuator and associated cathode follower, a two-stage final amplifier, a time-mark amplifier and four cathode-follower voltage regulators.

In order to reconcile the inherently conflicting problems of maximum bandwidth and high dc gain with good stability, a switching system is incorporated which automatically removes the two-stage preamplifier whenever sufficient sensitivity can be attained without it. This same switch (VERT. DEFL. SENSITIVITY) inserts appropriate rc-compensated attenuators in the circuit so that eight steps (approximately 10 db each) of sensitivity are available, ranging from 5 mv to 50 v per cm. Constant input impedance is maintained for all VERT. DEFL. SENSITIVITY settings. When the preamplifier is not used, i.e., for sensitivity below 0.15 v/cm, the pass band is 2 mc. For higher sensitivities, it is necessary to pay more attention to grid current stability, hum, microphonics, etc., and suitable high-conductance tubes are not available for the first preamplifier stage. Therefore, in order to obtain the desired gain, the pass band is reduced to 1 mc.

### Input Circuit

Flexible design of the Type 512 input circuit permits either single-ended or balanced (differential) signal input connection and positive or negative calibrator connection.

Frequency-compensated signal-input probes are supplied to provide reduced loading on the circuit under observation. They consist of 9-megohm series resistors paralleled with compensating capacitors, and provide an input im-

pedance of 10 megohms shunted by 14  $\mu\text{f}$ . With the VERTICAL INPUT switch (SW1) in position A, INPUT A is connected to grid No. 1 of V1 via the AC-DC switch, and the connection to grid 1 of V2 is grounded. In the +CAL. position, the output of the calibrator is connected to V1 (when the CAL. switch is set at NORM.), and the input to V2 is grounded. When SW1 is in the -CAL. position, opposite connections are made. With the INPUT switch in the A-B position, INPUT A is connected to grid No. 1 of V1 and INPUT B to grid No. 1 of V2. When amplification of the ac component only is desired, SW2 (AC-DC) permits insertion of coupling capacitors C1, C2, C7 and C8. This prevents drift in the preamplifier from changing the output positioning and also permits the use of full gain to observe signals such as power-supply ripple, when otherwise the dc component would exceed the range of the POSITION control and deflect the trace off the crt screen.

### Preamplifier

Drift due to grid current in V1 and V2 is minimized by the tube type selection, and by operating the plates and screens at low voltage. Grid-current limiting resistors R1.1 and R2.1 permit rapid recovery of positioning in case a large potential is inadvertently applied to the preamplifier. C3 and C4 are used to provide the same input capacitance when the preamplifier is in use, as when it is switched out in the first five positions of SW3. A balanced output at the plates of V1 and V2 is secured by cathode coupling due to the common resistor R3, when either single or balanced input is employed. The DIFF. BAL. control, R4, enables the gain of V1 and V2 to be adjusted to compensate for variation in tube characteristics, and thus allows the operator to realize maximum benefit from the differential-input connection.

V1 and V2 are coupled directly to the 2nd stage, V3 and V4, via the parasitic suppressors, R9 and R10. GAIN ADJ. A, R15, permits the degeneration in the cathode circuit V3 and V4 to be varied, thus controlling the overall gain of the preamplifier. In the 6th position (0.05-0.15 v/cm) of SW3 (VERT. DEFL. SENSITIVITY), additional degeneration is introduced in the second stage as a means of reducing the gain by a factor of three. This additional degeneration

is provided by R17 and R18. R17, marked GAIN ADJ. B, is variable, allowing the sensitivity to be individually adjusted in this position of SW3. L1 provides further increase in degeneration at high frequencies, thus compensating for shunt capacitance in the circuit. Overall high-frequency compensation of the preamplifier is accomplished by the adjustable inductors L3 and L4.

A voltage divider, R25, R26, R27 and R28, frequency compensated by C5 and C6 is employed so that the average output voltage of the preamplifier will be at ground potential. This method permits operation of the cathode follower stage input at ground potential, allowing signal-input connection direct to the cathode follower grid when the gain of the first and second stages is not needed.

Adjustment of the preamplifier balance is provided by two potentiometers, the PRE-AMP. BALANCE, R20, and the AUX. PRE-AMP. BAL., R20.1 in instruments SN189 and up. (Earlier instruments did not have R20.1). These controls are connected so that, depending on their adjustment, they either add to or subtract from the potential which would otherwise be present at the plates of V1 and V2. The use of two controls allows initial balance to be secured by adjusting the screwdriver control, R20.1, with the panel control R20, centered. This makes available the full range of R20 to compensate for possible changes in tubes and other components.

### Attenuator

All input signals and calibrating voltages pass through a five-section frequency-compensated attenuator. The attenuation ratios are 1:1, 3:1, 10:1, 30:1 and 100:1. Each section is designed to have an input resistance of 1 megohm shunted by a capacitance of 40  $\mu\text{f}$  when connected to the cathode-follower stage input circuit. Variable trimmers permit the capacitive divider ratio to be adjusted to equal the resistive divider frequency. Other variable capacitors shunted across the input side of each section are adjusted to maintain a constant input capacitance for all attenuator settings.

The VERT. DEFL. SENSITIVITY switch, SW3, combines the functions of shifting the input

connections, changing the second-stage gain and selecting the appropriate attenuator section, thus providing a very wide adjustment of sensitivity with a single control.

### Cathode Follower Stage

The sensitivity (gain) control provided by the VERT. DEFL. SENSITIVITY switch consists of 8 steps of approximately 10db each. To provide continuously variable control, a dual potentiometer, R53 and R54 designated VERT. AMPL. ATTEN., is employed to fill in between the steps of SW3.

The cathode followers V5 and V6 provide a low-impedance circuit for the VERT. AMPL. ATTEN. This is necessary because R53 and R54 must be relatively low resistance to prevent stray capacitances from appreciably restricting the high-frequency response. R52 limits the maximum attenuation of this control, and thus limits the output voltage required of the previous circuits to a value well below the point of overload.

In a direct-coupled amplifier, any unbalance of the circuits will be acted upon in the same manner as a signal, and consequently a change in the output voltage (vertical position) will occur when the gain is varied. A potentiometer, R51, labeled C. F. ADJ., is provided in the Type 512 to permit the cathode voltages of V5 and V6 to be made equal, thus making position independent of the VERT. AMPL. ATTEN. setting.

Since these tubes may exhibit small variations which would cause unbalance of the circuit, screwdriver access to R51 is provided at the front of the instrument (SN1985 and up) or through the right side of the cabinet (below SN 1985).

### Final Amplifier

A balanced output at the plates of the third stage, V7 and V8, with either single or balanced input, is secured by the use of a cathode resistor, R55, which is common to both tubes.

Since the third stage is directly coupled to the fourth (output) stage, any change in balance of the third stage will be present in amplified form at



the output. Therefore, it is possible to employ a potentiometer, R56, in the cathode circuit of V7 and V8 as a vertical-position control. R57 limits the range of positioning, making the adjustment of R56 less critical.

In instruments SN 449 and higher, potentiometer R61.2, labeled 3RD STAGE BAL., employed in the same type of circuit as the PRE-AMP. BAL. permits correction of any unbalance in the third stage due to mismatch of V7 and V8.

The third-stage plate-supply voltage is made as low as is consistent with an adequate undistorted output, to make available increased plate voltage for the fourth stage, thus permitting maximum overall undistorted output.

Shunt compensation provided by the variable inductors, L5 and L6, permits a bandwidth of 2 megacycles and rise time of .2 microseconds to be achieved in the final amplifier.

Since the average plate potential of the output stage is about +150 volts, current limiting resistors, R69 and R70, are provided between the plates and the output jacks of the Type 512, to prevent short-circuit hazard. Capacitors C39 and C40 prevent loss of high frequencies which would otherwise occur due to shunt capacitances of the cathode-ray-tube deflection plates.

#### Time-Marker Input

A means of inserting time-marker pulses without affecting the balance of the amplifier circuits is provided by V13 which is connected to the tapped plate load resistor of V7. The divider, R83 and R84, maintains grid 1 of V13 at about -6 volts, which is well beyond plate-current cutoff. When a marker pulse having sufficient amplitude to overcome this bias is applied to the grid via the TIME MARK INPUT connector, it appears in amplified form at the output of the Type 512.

#### Cathode-Follower Voltage Regulators

Reduced voltages at good regulation (low impedance) are required for the plate and screen supplies of the first, second, cathode-follower, and third stages. The plus 35-volt supply for the first stage, V1 and V2, is obtained from

one section of the dual triode, V11, which is operated as a cathode follower. The output voltage at the cathode is determined by the grid voltage, which is set by the divider, R73 and R74. Bypass capacitor C41 reduces ripple due to electrostatic pickup of stray fields.

The other section of V11 provides plate and screen voltage for V2 and V3 in a similar manner, except that part of the current is supplied through a shunt resistor, R77.

The dual triode, V12, operates in the same fashion, supplying the cathode-follower stage and the third stage.

#### Calibrator

Accurate measurement of signal amplitude in the Type 512 is made possible by means of the built-in square-wave calibrator, consisting of V115, V116, and associated circuits, located on the rear of the sweep chassis. The square wave of approximately 1 kc used for the calibrating voltage is generated by a free-running triode multivibrator, V115. A series limiting grid resistor, R182, is used to reduce the loading effect of the coupling capacitor, C125, thus providing a waveform with a sharp leading edge. This resistor affects the symmetry of the output, so that it is necessary to make timing resistors R181 and R185 unequal in order to obtain a symmetrical output. Since precise symmetry is not required, no provision is made to adjust the duration of the positive and negative portions of the waveform.

Since the square-wave output is to be used for amplitude comparison and adjustment of frequency-compensated attenuators, it is essential for the output waveform to be accurate, and to have a means of setting and maintaining the maximum output level at the desired value of 50 volts. This is accomplished in the diode limiter and output cathode-follower stages using the dual triode V116.

The output of the multivibrator is fed to the grid of the output cathode follower via C127 and a series limiting resistor, R190. A divider, R185.1 and R186, maintains the signal at proper operating level for the diode-connected limiter

section of V116. Since the voltage at the diode plate cannot rise appreciably above the cathode, maximum positive amplitude is determined by the cathode potential, which is set by the divider, R187, R188, and R189. A potentiometer, R188, allows the amplitude to be accurately adjusted. Since the limiting action of the diode occurs at a point well below the maximum amplitude of the multivibrator output, the positive portion of the waveform applied to the cathode-follower grid has a flat top and square corners. The maximum negative amplitude of this signal drives the cathode-follower grid to well below cathode current cut-off. This results in a clean square-wave output as the negative portion is held at ground potential, and the positive is a replica of the diode-limited waveform at the cathode-follower grid.

Output voltage of the calibrator is controlled by the CAL. RANGE step attenuator, R191, and the CAL. VOLTAGE potentiometer, R192.

Excellent accuracy is provided by the use of 1% tolerance resistors in R191, and by a sufficient number of steps so that the minimum setting of the CAL. VOLTAGE control never need be under 30% of the full scale.

A front panel toggle switch, SW105, labeled CAL., operates in conjunction with the VERTICAL INPUT switch, SW1, to apply the calibrator output to either V1 or V2 with the CAL. switch at NORM. and the INPUT switch in + or -CAL. position. In the A or A-B INPUT positions, the +250-volt supply lead is opened by SW1, and the CAL. switch must be set to EXT. to permit the calibrator to function.

When the EXT. position is used, the lead to SW1 is disconnected from the calibrator and grounded to prevent coupling to the amplifier input. The calibrator voltage is available for external use at the CAL. OUTPUT connector on the front panel.

## POWER SUPPLY

### -150-Volt Supply

In order to make the operation of the Type 512 independent of the line-voltage fluctuations over the range of 105 to 125 volts, electronically-regulated direct current is supplied to all plate, screen, and bias circuits, as well as the heaters of the tubes in first, second, cathode-follower, and third stages of the vertical amplifier.

Four separate power circuits are used, providing:

1. -150 volts at 200 ma for the tube heaters and bias circuits.
2. +250 volts at 190 ma for the plate and screen circuits.
3. +450 volts at 8 ma for the sweep amplifier plate circuit.
4. -1500 volts at 1500  $\mu$ a for the cathode-ray tube and sweep-amplifier neon-lamp coupling circuits. +1500 volts for the crt accelerating anode.

In the -150-volt supply, two rectifier tubes are used in a full-wave circuit. C211 reduces the 120-cycle ripple to about 9 volts peak to peak. The electronic regulator further reduces the ripple to less than 0.1 volt. In this circuit, the cathode of V212 is maintained at a fixed potential by the voltage reference tube, V213. Any fluctuations in the -150-volt supply are impressed on the grid of V212 via the divider, R224, R225 and R226, and the series resistor, R223, then are amplified and applied, opposite in phase, to the grid of the series regulator, V206A. Thus, the drop across V206A is increased when the -150-volt output is high and decreased when it is low, resulting in a stabilized output voltage. The shunt resistor, R220, is employed to reduce the current required of V206A. Potentiometer, R225, labeled ADJ. TO -150 V., permits accurate adjustment of the output voltage, and has sufficient range to compensate for variation in tube characteristics.



### + 250-Volt Supply

DC for the +250-volt supply is obtained from V207 and V208. The output of the -150-volt supply serves as a reference voltage for the regulator, V206B and V209. Any fluctuation on the +250-volt output is applied to V209 grid via the divider R216 and R217, and acts to stabilize the output voltage in the same manner as in the -150-volt regulator previously discussed.

### + 450-Volt Supply

The +450 volts required for the sweep amplifier is obtained by adding a 200-volt regulated supply to the +250-volt output. Rectified current is supplied by V204 in a half-wave circuit. The cathode of the regulator amplifier (one-half of V205) is held constant as it is connected to the output of the +250-volt supply. Any fluctuations appearing at the cathode of the series regulator (the other half of V205) are impressed on the amplifier grid via the divider R208 and R209. This fluctuation signal is amplified, inverted, and applied to the series-regulator grid, controlling the regulator output voltage in the same manner described under "-150-Volt Supply".

### High Voltage Supply

Plus and minus 1500-volt cathode ray tube potentials are supplied by an oscillator power supply, using V201 in a conventional Hartley

circuit. The plate and screen of the oscillator tube are supplied from the +250-volt regulated bus, and the high voltage output is thus unaffected by line-voltage fluctuations. Oscillator frequency for instruments S/N 101-2146 is approximately 2 kc. For all later instruments, the oscillator frequency is about 70 kc.

Below S/N 2147, there was no provision for self-regulation of the high voltage supply. In instruments S/N 2147 and above, however, electronic regulation is provided by V225, an error-amplifier which controls the screen voltage of oscillator V201. A part of the negative high voltage output is fed to the grid of V225A through the resistive divider composed of R253, R254, R255 and R256, setting the grid of V225A at approximately -150 volts. Since the cathode of V225A is held at -150 volts by the regulated supply bus any fluctuations of voltage presented to the grid will appear amplified and inverted at the plate. This amplified and inverted signal is direct coupled to the grid of V225B. Any variation in the current drawn by V225B will appear as a voltage change at the screen of the oscillator output. The phasing of the feedback loop is such that a drop in output voltage will increase the oscillator output or an increase in output voltage will decrease the oscillator output. Therefore, changes in output voltage due to load variations are reduced to a minimum. Potentiometer R254, labeled -1500 ADJ., permits accurate adjustment of the output voltage. There is no output voltage adjustment in instruments below S/N 2147.

## ADJUSTMENTS AND MAINTENANCE

**CAUTION—VOLTAGES HIGH ENOUGH TO BE DANGEROUS ARE PRESENT IN THIS INSTRUMENT. SINCE MUCH MAINTENANCE MUST OF NECESSITY BE DONE WITH THE CASE REMOVED, GREAT CARE SHOULD BE TAKEN. USE ONLY INSULATED TOOLS, STAND ON A DRY FLOOR, AND IF POSSIBLE KEEP ONE HAND IN YOUR POCKET.**

### Replacement of Components

Most of the components used in the construction of TEKTRONIX instruments are standard parts obtainable from any well-equipped parts distributor. Some of the components carrying 1% and 2% tolerances may not be so readily obtainable but may be purchased from the manufacturer at these tolerances. The remainder of the low-tolerance components are standard 10%- and 20%-tolerance parts that are checked at the factory for proper value or performance. Replacement parts are available on order from the factory at current net prices but in the case of standard parts it is probably more economical of time to purchase them locally. It is not feasible to attempt to check out low-tolerance parts or matched pairs without a reasonably large stock to choose from as the rejection percentage is quite high in most cases.

This manual has been prepared to cover TEKTRONIX Type 512 Oscilloscopes of all serial number ranges. Diagrams, parts lists and text have been expanded to incorporate all instrument modifications adopted during the course of manufacture. The serial ranges of instruments to which modifications were applied before shipping from the factory have been noted wherever necessary.

However, because many instruments have been modified in the field and out of serial sequence, component values and circuitry of a given instrument may differ considerably from those indicated in this manual for its serial number. In some cases, circuits were handtailored during the original factory calibration and test procedure. You will find that this manual has been hand-corrected if necessary, to show these changes, according to factory records.

To assure that you will receive correct replacement parts with the minimum delay, therefore, it is important that you include a full description of the part and its appropriate 6-digit TEKTRONIX Part Number as well as the circuit-number, instrument type and instrument serial number when you order.

Equivalent parts, supplied by the factory when the exact replacement parts ordered are not available, will be accompanied by an explanation and will be directly interchangeable in most cases.



## Removal of the Case

Set the oscilloscope face downward on a padded flat surface, remove the access panel jumper plugs and the two screws in the bottom, then lift off the case.

## Power Supply

Adjustments of the output voltages of the regulated supplies are provided by potentiometers R225, labeled ADJ. to -150 V, and R254 (SN 2147 and up), labeled 1500 V ADJ. The plus 250- and 450-volt supplies are dependent on the adjustment of the minus 150-volt supply. A voltmeter with an internal impedance of at least 20,000  $\Omega$  per volt should be used when measuring the minus 1500-volt supply.

## Operation on 210-250-Volt 50-60-Cycle Line

The Type 512 power transformer is wound with two 117-volt primaries. These windings are ordinarily connected in parallel at the factory for 117-volt operation. If 234-volt operation is desired, remove the jumpers connecting terminals 1 to 2 and 3 to 4. Connect terminal 2 directly to terminal 3. With the line still connected to terminals 1 and 4, the instrument is now ready for 234-volt operation.

## Calibrator

Before adjustments are made on the vertical amplifier, it is well to check the output adjustment of the calibrator. This may be conveniently done by a comparison between the output of the calibrator and a known dc voltage. A suggested dc source is a 45-volt B battery and an accurate dc voltmeter. As an example then, let us assume the dc voltmeter indicated 47 volts. Set the calibrator controls to an indicated 47 volts. Connect the battery (with voltmeter connected) negative terminal to GND. and positive terminal directly to INPUT A (no probe). Set the vertical amplifier gain such that the deflection will be large enough for an accurate comparison. The comparison may readily be made by switching the VERTICAL INPUT selector switch between A and +CAL. If satisfactory agreement is not indicated, an adjustment may be made by means of R188, labeled CAL. ADJ. and located on the sweep chassis.

## Vertical Amplifier

### 1. Differential-and-DC-Balance Adjustments

The several stages of the Type 512 vertical amplifier are balanced and direct coupled. To avoid shifts of position with change of gain, each stage should be in balance. The PRE-AMP BALANCE should be used only as a balance control and any desired positioning should be done with the VERT. POSITION control which follows the amplifier gain adjustments and hence is not affected by them. Conversely, any unbalance preceding either the step attenuator or the variable attenuator will be acted upon exactly the same as a signal and a change of position will accompany any change of gain. A complete check of the balance of each stage may best be made by starting at the output of the amplifier and progressing toward the input. A suggested procedure follows:

#### a. Output-Stage Balance

Balance of the output stage, V9 and V10 may be checked as follows: Connect the grids of V9 and V10 together. Now short the Y1 and Y2 plates and observe the deflection of the trace. If more than 1 cm deflection occurs, replacement of one or both of the output tubes is indicated.

#### b. Third-Stage Balance

To check the balance of V7 and V8, short the top terminals of the dual gain-control potentiometers R53 and R54 marked VERT. AMPL. ATTEN. and observe whether or not the vertical position control, R56 has adequate range in each direction. If not, the range of R56 should be equalized by adjusting R61.2, labeled 3rd STAGE BAL. This control is incorporated in all instruments above SN 448. In earlier instruments it will be necessary to select tubes to obtain proper balance.

#### c. VERT. AMP. ATTEN. Cathode-Follower Balance

##### Adjustment

With the VERT. DEFL. SENS. switch in the .15-.5 position, adjust R51 (marked C.F. ADJ.)

so that varying the setting of the VERT. AMPL. ATTEN. or shorting its top terminals does not shift the vertical position of the trace. If proper adjustment cannot be obtained, V5 and V6 must be replaced with more nearly balanced tubes.

#### d. Second-Stage Balance

Balance of the second stage may be checked by connecting together the grids and also the cathodes of V3 and V4. The amount of unbalance is indicated by the change in vertical positioning when the VERT. DEFL. SENSITIVITY switch is moved from the .15-.5 to the .015-.05 position. Although the PRE-AMP BALANCE (and the AUX. PRE-AMP BAL. above SN 189) will compensate for considerable unbalance in the second stage, it is desirable to install a more nearly matched pair of tubes if the unbalance exceeds plus or minus 2 1/2 cm.

#### e. Differential-Balance Adjustment

Set the VERT. DEFL. SENSITIVITY switch in the .005-.015 position, the VERTICAL INPUT switch in the A-B position, the AC-DC switch in the AC position, and the toggle switch marked CAL. to the EXT. position. Center the PRE-AMP BALANCE control, R20. Connect the CAL. OUTPUT to both INPUT A and INPUT B. Set the calibrator for an output of 5 volts. Slowly adjust R4, located on the right side and marked DIF. BAL., for minimum deflection of the trace. When an approximate adjustment is obtained, switch the AC-DC switch to DC and adjust the AUX. PRE-AMP BAL.\* control (R20.1) for centering of the trace. Alternate or simultaneous adjustment of this control and the DIF. BAL. control may be necessary to secure the best differential balance, as the DIF. BAL. control has a large effect on the positioning and the AUX. PRE-AMP BAL.\* has a small effect on the differential balance. If the proper adjustments of either the DIF. BAL. or the AUX. PRE-AMP BAL.\* are found to be beyond the range of the controls, it will be necessary to substitute a more nearly matched pair of tubes

\*In instruments below SN189, it will be necessary to make these adjustments with the PRE-AMP BALANCE control (R20).

for V1 and V2. The use of the AUX. PRE-AMP BAL. to secure initial balance, with the PRE-AMP BALANCE (R20) centered, makes available the full range of R20 to compensate for possible changes in tube characteristics.

#### f. .05-.15 BAL. Adjustment

In the .05-.15 position of the VERT. DEFL. SENSITIVITY switch, additional degeneration is introduced in the second stage of the preamplifier as a means of reducing the gain by a factor of three. This is used rather than the next attenuator step in order to reduce the maximum output voltage required of the preamplifier. A balancing control, R13, is provided which permits maintaining the trace in the same vertical position in the .05-.15 as in the other positions of the VERT. DEFL. SENSITIVITY switch. The following procedure is recommended: Set the VERT. DEFL. SENSITIVITY in the .15-.5 position and center the trace. Change the VERT. DEFL. SENSITIVITY to the .005-.015 position and center the trace with the AUX. PRE-AMP BAL. control. Set the VERT. DEFL. SENSITIVITY in the .05-.15 position and center the trace with R13, marked .05-.15 BAL. Repeat until the trace remains centered in all three positions.

#### g. Readjust Differential Balance

Since a change in setting of the .05-.15 BAL. adjustment causes a slight change in the differential balance, it is desirable to readjust the DIF. BAL. control, R4, as explained in section e.

NOTE--One pair 5879 (or 6AK6 below SN2526) and one pair 12AU6 matched spare tubes are included with the Type 512. These tubes, located inside the instrument on a bracket near the crt socket, are selected to have characteristics similar to the matched tubes installed in the vertical amplifier. If it becomes necessary to replace a defective tube in any of the balanced stages, it is usually desirable to install the spare pair and order a replacement matched pair from the factory. The remaining good tube, which has been removed from the amplifier, will be useful as an emergency spare.





## 2. Gain Adjustments

Two gain adjustments other than the panel controls are included in the Type 512 Oscilloscope. An adjustment of the overall gain of the instrument is provided by a variable resistor R15, marked GAIN ADJ. A. The gain of the Type 512 may be checked against the self contained calibrator. The maximum sensitivity should be adjusted to 5 mv/cm.

The second adjustment, R17, marked GAIN ADJ. B, provides an adjustment of the gain when VERT. DEFL. SENSITIVITY is in the .05-.15 position only. With the VERT. AMPL. ATTEN. fully clockwise, adjust R17 for a deflection sensitivity of 0.05 v per cm.

## 3. Compensation of the RC Attenuator and Voltage Divider Circuits.

The various attenuators in the Type 512 are of the rc type in which the resistor divider ratio is equal to the capacitor divider ratio and hence the voltage division is constant for any frequency from zero to well above the requirements of the Type 512. Adjustment of these attenuators is readily made by observation of their square-wave response. The self-contained calibrator in the Type 512 is a suitable square-wave source. A vertical deflection of a 3 to 5 cm is recommended. When the variable capacitors in the attenuators are properly adjusted, a square wave will be correctly reproduced by the oscilloscope. If the capacitive divider has a lower attenuation ratio than the resistive divider, a spike appears on the corner of the leading edge. If the capacitive divider has a higher attenuation, the corner of the leading edge is rounded.

To simulate the presence of the case, a metal sheet should be placed on top of the instrument during these adjustments. A hole in the sheet will be required for access to some of the variable capacitors.

**CAUTION**—THE PREAMP SHIELD MUST BE IN PLACE DURING ADJUSTMENT.

a. The A-and B-input capacitances of the third stage are equalized and the probes adjusted with

the VERT. DEFL. SENSITIVITY switch in the .15-.5 position (input direct to the third stage). Attach one of the probes to INPUT A and connect it to CAL. OUTPUT. With the sweep time set at about 1 millisecond/cm (10 cycles of the square wave for 10-cm deflection) and C37 at 1/3 capacitance, adjust the probe capacitor, C9. Move the probe to INPUT B, ground INPUT A, and adjust C38. If proper adjustment cannot be obtained, reset C37 and readjust the probe and C38. If the setting of one probe is changed, the other should be adjusted to correspond.

b. With VERTICAL INPUT set at either + or -CAL. and the VERT. DEFL. SENSITIVITY switch in the .005-.015 position, adjust C5 and C6 using a sweep time of 0.1 to 0.2 milliseconds/cm. Use an insulated screwdriver. These capacitors are complementary in action and should be at about equal settings.

Using a sweep time of 0.1 to 0.2 milliseconds/cm adjust the attenuator series capacitors. The +CAL. input may be used for C13, C17, C25 and C33, and the -CAL. for C14, C18, C26 and C34.

NOTE—Attenuator adjustments are listed in order of increasing attenuation, corresponding respectively to the .5-1.5, 1.5-5, 5-15 and 15-50 positions of the VERT. DEFL. SENSITIVITY switch.

d. Attach one of the probes to INPUT A, connect it to CAL. OUTPUT, set the sweep time at about 1 millisecond/cm and adjust the parallel attenuator capacitors C11, C15, C23 and C31. Set VERT. DEFL. SENSITIVITY at .005-.015 and adjust input capacitor, C3. Move the probe to INPUT B, ground INPUT A and adjust C12, C16, C24 and C32. Move VERT. DEFL. SENSITIVITY to .005-.015 and adjust C4.

Greater accuracy in the adjustment of C31 and C32 may be obtained by providing increased signal input and therefore greater vertical deflection. A convenient method is to substitute a 1-megohm variable resistor shunted by a 50  $\mu$ f capacitor for the probe. With VERT. DEFL. SENSITIVITY in the .15-.5 position, adjust the variable resistor until the square wave is properly reproduced, then proceed with the adjustment of C31 and C32.

## 4. High Frequency Response

The Type 512 vertical amplifier employs shunt compensation to improve the high-frequency characteristics, and is adjusted for best transient response rather than greatest bandwidth. This is accomplished by observing the response to a square-wave signal of about 100 kc having a rise time of 0.1 microsecond or less. The TEKTRONIX Type 104 or Type 105 Square Wave Generators provide a suitable signal.

a. Set the sweep time at 3 microseconds/cm, the VERT. DEFL. SENSITIVITY at .15-.5 and adjust L5 and L6 until the corner of the leading edge is square. These inductors are complementary and interdependent in action and should be at about equal settings.

b. Set VERT. DEFL. SENSITIVITY at .015-.05 and adjust L3 and L4 in a similar manner.

c. Set VERT. DEFL. SENSITIVITY at .05-.15 and adjust L1.

## HORIZONTAL DEFLECTION SYSTEM

### Timing-Series Capacitors

Since 1954, we have manufactured our own timing capacitors with the characteristics needed to maintain sweep-time accuracy and linearity. The capacitance ratio between capacitors used is accurate within half of one per cent so that the time-base calibrations will be right at all speeds. Most capacitors change value with voltage, temperature, and age. Variation of capacitance with voltage is particularly undesirable because it causes nonlinearity of the time-base sawtooth. Our timing capacitors are especially free from this voltage effect. They also have minimum temperature and aging variations.

Starting with SN 2999, timing capacitors C119, C120, and C121 are enclosed as a unit in a single sealed can. If you need to replace any one of these you must replace all three. C118 may be composed of two capacitors, chosen to have the right characteristics and capacitance value when connected in parallel. We therefore recommend that you obtain replacements for this capacitor from TEKTRONIX. Be sure to include the instrument serial number with your order.

These TEKTRONIX units are now supplied on all orders for Type 512 timing capacitors. Special installation instructions for instruments below SN 2999 are provided.

### Sweep

1. Adjustment of the sweep amplifier to compensate for variation of its gain or the sensitivity

of the crt is provided by R176, marked SWEEP AMPL. GAIN. The gain may be set to the specified 1.0 volts per cm (5ABP CRT) or 1.5 v/cm (5CP CRT) deflection using the calibrator as a source of known voltage. Connect CAL. OUTPUT to EXT. SWEEP IN. With the sweep range switch set to EXT., the CAL. toggle switch to EXT., the calibrator output adjusted to 10 volts (for 5ABP) or 15 volts (for 5CP) and with the EXT. SWEEP ATTEN. set for maximum gain, adjust R176 (SWEEP AMPL. GAIN) so that a deflection of 10 cm is obtained. This adjustment should be checked whenever the sweep amplifier or cathode-ray tubes are changed.

**CAUTION**—THE CRT DEFLECTION SENSITIVITY WILL BE CHANGED IF THE INTENSITY CONTROL IS ADVANCED EXCESSIVELY.

2. Two screwdriver adjustments, located on the sweep chassis and marked SWEEP TIME A (R163) and SWEEP TIME B (R159) permit adjustment of the sweep speed to correspond to the calibration of the SWEEP TIME/CM dial. R163 has a large effect on the "fast" end of the SWEEP TIME/CM potentiometer, R161, and a small effect on the "slow" end, while R159 has the opposite action, therefore adjustment of either control requires a minor readjustment of the other. These adjustments may be made at any convenient setting of the SWEEP RANGE switch except 3-10 microseconds and 10-30 microseconds. If an accurate oscillator or time-mark generator is not available, the 60-cycle line may be used as a standard.



a. If it is desired to use the 60-cycle line, connect any convenient source of 60-cycle voltage, such as the heater bus of the instrument, to the vertical-amplifier input. Set the SWEEP RANGE switch to the 10-30 millisecond position, and the SWEEP TIME/CM dial at 1.0. Adjust SWEEP TIME A so that 6 cycles correspond to 10 cm of the sweep. Set the SWEEP TIME/CM dial to 3.0 and adjust SWEEP TIME B so that 18 cycles correspond to 10 cm of the sweep. Repeat the above procedure until accuracy is obtained at both ends of the scale.

b. The sweep time in the 3-10 and 10-30 microsecond positions and the magnified sweep in the 30 microsecond to .1 millisecond and the .1-.3 millisecond positions is controlled by the variable ceramic capacitor, C117. The magnified sweep in the 3-10 and 10-30 microsecond positions is controlled by the variable ceramic capacitor C116. These adjustments may be made with the aid of a calibrated oscillator of suitable frequency. A commonly available instrument suitable for the purpose is the Army Frequency Meter BC221 or the Navy equivalent, Type LM. If one of the above instruments is available, set it to a frequency of 166.67 kc. Set the Sweep range switch to 3-10 microseconds and the SWEEP TIME/CM dial to 1. Adjust C117 so that 5 cycles of the observed waveform will extend over 10 cm of the sweep.

c. Change the SWEEP RANGE switch to the 10-30 microsecond position and the MAGNIFIER switch to IN. Set the SWEEP MAGNIFIER position to about the center of its range and adjust C116 so that 3 cycles of the observed waveform extend over 10 cm of the sweep.

3. A screwdriver control, R123, located on the sweep chassis and marked MAG. POS. is provided to adjust the initial position of the magnified sweep to correspond with that of the normal sweep.

### Blanking

Blanking in the Type 512 is accomplished by means of an rf oscillator, transmission line, and rectifier system which provide cut-off bias for the crt during standby and flyback periods. During the period of the sweep the oscillator, V107 is blocked by a negative voltage applied to the suppressor. The oscillator and rectifier circuits may be tuned to the same frequency by means of the variable slugs in coils L101 and L301.

Set the SWEEP STABILITY fully counterclockwise and the BLANKING control fully clockwise. Turn the HOR. POSITION control clockwise until the spot has moved onto the crt screen. Turning the BLANKING control counterclockwise should cause the spot to be blanked out. Turn the BLANKING control slightly past the point where the spot disappears and then advance the INTENSITY control until a spot is faintly visible. Adjust L101 and/or L301 for minimum intensity of the spot, advancing the INTENSITY control as necessary.

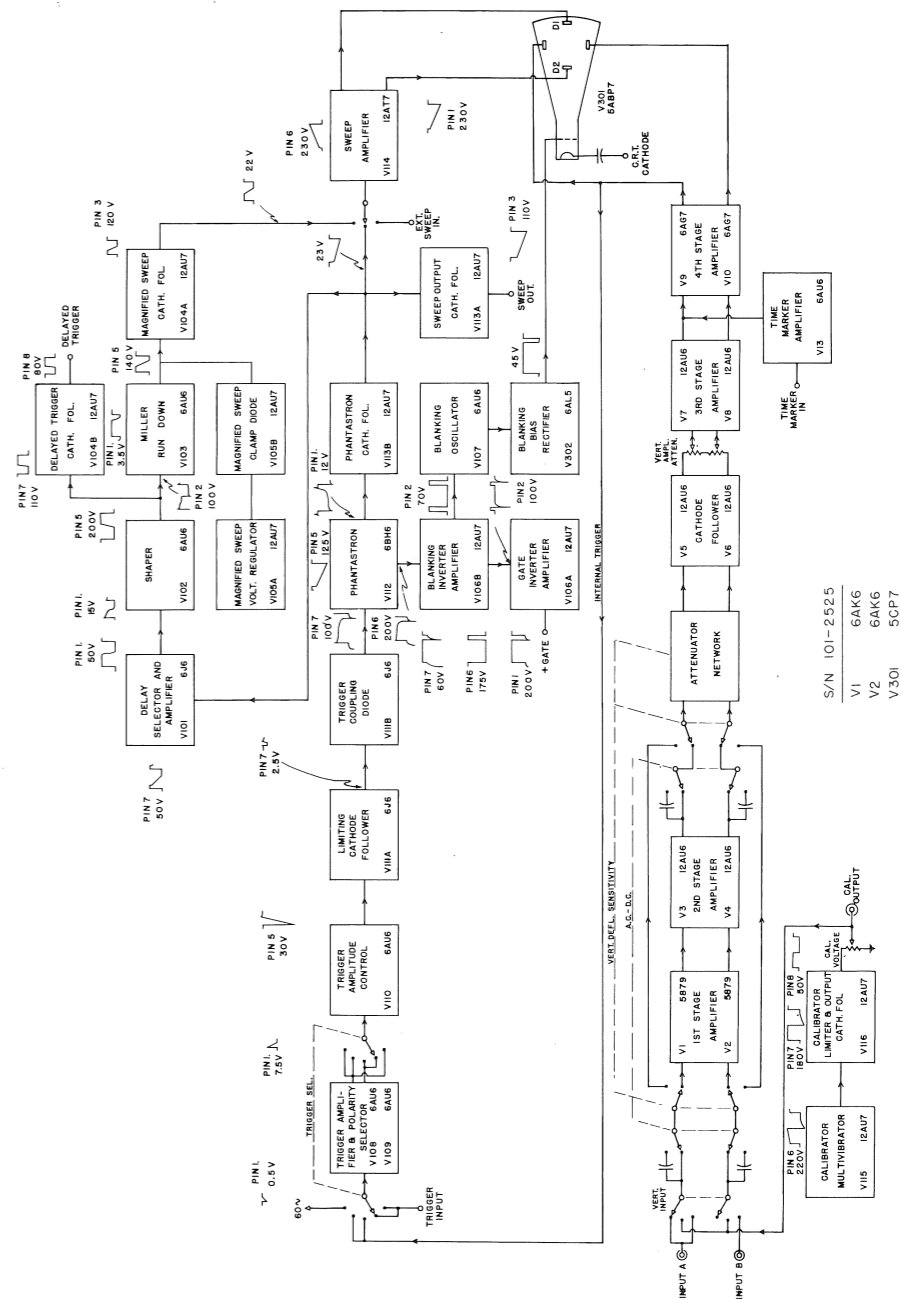

## SWEEP CAL. & CRT

### ABBREVIATIONS

Cer	Ceramic	m	milli or 10 <sup>-3</sup>
Comp.	Composition	Ω	ohm
EMC	Electrolytic, metal cased	PBT	Paper, "Bathtub"
f	Farad	PMC	Paper, metal cased
GMV	Guaranteed minimum value	Poly.	Polystyrene
h	Henry	Prec.	Precision
k	Kilohm or 10 <sup>3</sup> ohms	PT	Paper Tubular
M/Cer.	Mica or Ceramic	v	Working volts DC
meg	Megohm or 10 <sup>6</sup> ohms	Var.	Variable
μ	Micro. or 10 <sup>-6</sup>	w	Watt
μμ	Micromicro or 10 <sup>-12</sup>	WW	Wire-wound

### Special Notes and Symbols

+	and up.
†	Approximate serial number.
X000	Part first added after this serial number.
000X	Part removed at this serial number.
(Mod. w/)	Simple replacement not recommended. Modify to value for later instruments and change other listed parts to match.

							Capacitors	Order Parts by Number
C101	101-300†	0.1 μf	600 v	Fixed	PT	20%	Use 285-526	
	301†-2082	0.1 μf	400 v	Fixed	PBT	20%	Use 285-526	
	2083 +	(1/3-3x0.1 μf) <sup>1</sup> 0.1 μf	400 v	Fixed	PT	20%	285-526	
C102	101 +	27 μf	400 v	Fixed	M/Cer	20%	281-513	
C103	101 +	20 μf (1/2-2x20 μf) <sup>2</sup>	450 v	Fixed	EMC	-20,+50%	290-037	
C104	101 +	27 μf	400 v	Fixed	M/Cer.	20%	281-513	
C104.1	101-300	.02 μf	600 v	Fixed	PT	20%	Use 285-526	
	301-2082	0.1 μf	400 v	Fixed	PBT	20%	Use 285-526	
	2083 +	(1/3-3x0.1 μf) <sup>1</sup> 0.1 μf	400 v	Fixed	PT	20%	285-526	
C105	101-1465X Replaced by C105.2	27 μf	400 v	Fixed	M/Cer.	20%	See C105.2	

<sup>1</sup>C101, C104.1 and C122

<sup>2</sup>C103 and C113



Capacitors (continued)

C105.1	101 +	.01 $\mu\text{f}$	400 v	Fixed	PT	20%	285-510
C105.2	X1466 +	3-12 $\mu\text{f}$	400 v	Var.	Cer.		281-007
C106	101 +	27 $\mu\text{f}$	400 v	Fixed	M/Cer.	20%	281-513
C107	101 +	27 $\mu\text{f}$	400 v	Fixed	M/Cer.	20%	281-513
C107.1	101-2640 2641 +	27 $\mu\text{f}$ 47 $\mu\text{f}$	400 v 400 v	Fixed Fixed	M/Cer. M/Cer.	20% 20%	Use 281-518 281-518
C108	101 +	100 $\mu\text{f}$	400 v	Fixed	Mica	10%	283-505
C108.1	101-2146† 2147† +	56 $\mu\text{f}$ 47 $\mu\text{f}$	400 v 400 v	Fixed Fixed	M/Cer. M/Cer.	20% 20%	Use 281-518 281-518
C109	101 +	47 $\mu\text{f}$	400 v	Fixed	M/Cer.	20%	281-518
C110	101 +	0.1 $\mu\text{f}$	600 v	Fixed	PT	20%	285-527
C111	101 +	0.1 $\mu\text{f}$	600 v	Fixed	PT	20%	285-527
C112	101-1291X Replaced by C112.1	12 $\mu\text{f}$	400 v	Fixed	M/Cer.	20%	} Mod w/R146, R147,R148
C112.1	1292-1985X	5-20 $\mu\text{f}$	500 v	Var.	Cer.		
C113	101 +	20 $\mu\text{f}$ (1/2-2x20 $\mu\text{f}$ ) <sup>2</sup>	450 v	Fixed	EMC	-20+50%	290-037
C114	101-1985 1986-2146† 2147† +	27 $\mu\text{f}$ 56 $\mu\text{f}$ 56 $\mu\text{f}$	400 v 400 v 400 v	Fixed Fixed Fixed	M/Cer. M/Cer. M/Cer.	20% 20% 10%	Use 281-521 Use 281-521 281-521
C116	101 +	7-45 $\mu\text{f}$	500 v	Var.	Cer.		281-012
C117	101 +	7-45 $\mu\text{f}$	500 v	Var.	Cer.		281-012
C117.1	101 +	56 $\mu\text{f}$	500 v	Fixed	M/Cer.	20%	281-521
C118	101 + Replacement	.001 $\mu\text{f}$ .001 $\mu\text{f}$	600 v 500 v	Fixed Fixed	Mica Cer.	3% 1/2%	Use 291-008 291-008
C119	101-2998 2999 +	.01 $\mu\text{f}$ .01 $\mu\text{f}$	600 v 400 v	Fixed Fixed	PT Mylar*	3% 1/2%	Use 291-003 291-003(Set)
C120	101-2998 2999 +	0.1 $\mu\text{f}$ 0.1 $\mu\text{f}$	600 v 400 v	Fixed Fixed	PT Mylar*	3% 1/2%	Use 291-003 291-003(Set)

\*Timing Series - See text.

<sup>2</sup>C103 and C113

Capacitors (continued)

C121	101-2998 2999 +	1.0 $\mu\text{f}$ 1.0 $\mu\text{f}$	600 v 400 v	Fixed Fixed	PMC Mylar*	3% 1/2%	Use 291-003 291-003(Set)
C122	101-300† 301† -2082  2083 +	0.1 $\mu\text{f}$ 0.1 $\mu\text{f}$ (1/3-3x0.1 $\mu\text{f}$ ) <sup>1</sup> 0.1 $\mu\text{f}$	600 v 400 v  400 v	Fixed Fixed  Fixed	PT PBT  PT	20% 20%  20%	Use 285-526 Use 285-526  285-526
C123	101 +	.001 $\mu\text{f}$	600 v	Fixed	PT	20%	285-501
C124	101 +	.001 $\mu\text{f}$	600 v	Fixed	PT	20%	285-501
C125	101-549 550-2010 2011-2146† 2147 +	250 $\mu\text{f}$ 220 $\mu\text{f}$ 330 $\mu\text{f}$ 330 $\mu\text{f}$	400 v 400 v 500 v 500 v	Fixed Fixed Fixed Fixed	Mica Mica Mica Mica	20% 20% 10% 20%	Use 283-518 Use 283-518 Use 283-518 283-518
C126	101-549 550-2010 2011-2146† 2147† +	250 $\mu\text{f}$ 220 $\mu\text{f}$ 330 $\mu\text{f}$ 330 $\mu\text{f}$	400 v 400 v 500 v 500 v	Fixed Fixed Fixed Fixed	Mica Mica Mica Mica	20% 20% 10% 20%	Use 283-518 Use 283-518 Use 283-518 283-518
C127	101 +	.01 $\mu\text{f}$	400 v	Fixed	PT	20%	285-510
C128	101-157  158-1031X Replaced by C128.1	0.1 $\mu\text{f}$  1.0 $\mu\text{f}$	400 v  400 v	Fixed  Fixed	PBT  PBT	20%  20%	See C128.1  See C128.1
C128.1	X1032 +	6.25 $\mu\text{f}$	300 v	Fixed	EMC	-20+50%	290-000
C129	101 +	40 $\mu\text{f}$ (2x20 $\mu\text{f}$ )	450 v	Fixed	EMC	-20+50%	290-037
C301	101 +	27 $\mu\text{f}$	400 v	Fixed	M/Cer.	20%	281-513
C302	101 +	27 $\mu\text{f}$	400 v	Fixed	M/Cer.	20%	281-513
C303	101 +	0.1 $\mu\text{f}$	2000 v	Fixed	PT	20%	285-530
C304	101-569 570-1204† 1205† +	0.1 $\mu\text{f}$ 0.1 $\mu\text{f}$ 0.1 $\mu\text{f}$	400 v 600 v 400 v	Fixed Fixed Fixed	PT PT PT	20% 20% 20%	285-526 Use 285-526 285-526

\*Timing Series - See text.

<sup>1</sup>C101, C104.1 and C122



Inductors

L101	101 +	4.8-9 $\mu$ h	Var.	114-020
L301	101 +	4.8-9 $\mu$ h	Var.	114-020

Resistors

R101	101 +	100 k	1 w	Fixed	Comp.	10%	304-104
R102	101 +	22 k	1 w	Fixed	Comp.	10%	304-223
R103	101 +	270 k	1/2 w	Fixed	Comp.	10%	302-274
R104	101 +	500 k	2 w	Var.	Comp.	20%	311-034
R105	101 +	33 k	1/2 w	Fixed	Comp.	10%	302-333
R106	101-2176 <sup>†</sup> 2177 +	1 meg 750 k	1/2 w 1/2 w	Fixed Fixed	Comp. Prec.	10% 1%	Mod w/R107 309-010
R107	101-2176 <sup>†</sup> 2177 +	680 k 490 k	1/2 w 1/2 w	Fixed Fixed	Comp. Prec.	10% 1%	Mod w/R106 309-002
R108	101 +	47 k	1 w	Fixed	Comp.	10%	304-473
R109	101-2743 2744 +	27 k 27 k	1 w 2 w	Fixed Fixed	Comp. Comp.	10% 10%	Use 306-273 306-273
R110	101-2902 2903 +	680 k 750 k	1/2 w 1/2 w	Fixed Fixed	Comp. Comp.	10% 5%	Use 301-754 301-754
R111	101 +	1 meg	1/2 w	Fixed	Comp.	10%	302-105
R113	101-2743 2744 +	27 k 27 k	1 w 2 w	Fixed Fixed	Comp. Comp.	10% 10%	Use 306-273 306-273
R114	101 +	220 k	1/2 w	Fixed	Comp.	10%	302-224
R115	101 +	1.5 meg	1/2 w	Fixed	Prec.	1%	309-017
R116	101 +	3.5 meg	1/2 w	Fixed	Prec.	1%	309-086
R117	101-129 130-999 1000-2525 2526 +	10 k 10 k 10.1 k 6.25 k	1/2 w 1/2 w 1/2 w 1/2 w	Fixed Fixed Fixed Fixed	Comp. Prec. Prec. Prec.	10% 1% 1% 1%	Mod w/R166 309-033
R118	101-129 130 +	47 k 45 k	1/2 w 1 w	Fixed Fixed	Comp. Prec.	10% 1%	Use 310-093 310-093

Resistors (continued)

R119	101 +	47 k	1 w	Fixed	Comp.	10%	304-473
R120	101 +	1.5 meg	1/2 w	Fixed	Comp.	10%	302-155
R121	101 +	1 meg	1/2 w	Fixed	Comp.	10%	302-105
R122	101 +	47 k	1 w	Fixed	Comp.	10%	304-473
R123	101 +	500 k	2 w	Var.	Comp.	20%	311-034
R124	101-149 150 +	1.0 meg 1.2 meg	1/2 w 1/2 w	Fixed Fixed	Comp. Comp.	10% 10%	Use 302-125 302-125
R125	101 +	1 meg	1/2 w	Fixed	Comp.	10%	302-105
R126	101 +	1.5 meg	1/2 w	Fixed	Comp.	10%	302-155
R127	101 +	1 meg	1/2 w	Fixed	Comp.	10%	302-105
R128	101 +	47 k	1 w	Fixed	Comp.	10%	304-473
R129	101 +	47 k	1 w	Fixed	Comp.	10%	304-473
R130	101 +	1.5 meg	1/2 w	Fixed	Comp.	10%	302-155
R131	101 +	1 meg	1/2 w	Fixed	Comp.	10%	302-105
R131.1	101 +	500 k	2 w	Var.	Comp.	20%	311-034
R131.2	101 +	100 k	1/2 w	Fixed	Comp.	10%	302-104
R131.3	101 +	680 k	1/2 w	Fixed	Comp.	10%	302-684
R132	101 +	10 k	1/2 w	Fixed	Comp.	10%	302-103
R133	101-2743 2744 +	27 k 27 k	1 w 2 w	Fixed Fixed	Comp. Comp.	10% 10%	Use 306-273 306-273
R134	101 +	10 k	2 w	Fixed	Comp.	10%	306-103
R135	101 +	1 meg	1/2 w	Fixed	Comp.	10%	302-105
R136	101 +	10 meg	1/2 w	Fixed	Comp.	10%	302-106
R137	101 +	1 meg	1/2 w	Fixed	Comp.	10%	302-105
R138	101 +	27 k	1 w	Fixed	Comp.	10%	304-273
R139	101 +	47 k	1 w	Fixed	Comp.	10%	304-473



Resistors (continued)

R140	101 +	68 k	1/2 w	Fixed	Comp.	10%	302-683
R141	101 +	27 k	1 w	Fixed	Comp.	10%	304-273
R142	101-298 † 299-448 † 449 † +	56 k 47 k 47 k	1/2 w 1/2 w 1/2 w	Fixed Fixed Fixed	Comp. Comp. Comp.	10% 5% 10%	Use 302-473 Use 302-473 302-473
R143	101 +	500 k	2 w	Var.	Comp.	20%	311-035
R144	101 +	390 k	1/2 w	Fixed	Comp.	10%	302-394
R145	101 +	1 meg	1/2 w	Fixed	Comp.	10%	302-105
R146	101-1985 1986 +	47 k 47 k	1 w 2 w	Fixed Fixed	Comp. Comp.	10% 10%*	Mod w/R147,R148 C112(C112.1) 312-538(Set)
R147	101-169 170-1985 1986 +	1.5 meg 1.5 meg 68 k	1/2 w 1/2 w 1 w	Fixed Fixed Fixed	Comp. Prec. Comp.	10% 1% 10%*	{ Mod w/R146,R148, C112(C112.1) 312-538(Set)
R148	101-169 170-1985X	1 meg 1.0 meg	1/2 w 1/2 w	Fixed Fixed	Comp. Prec.	10% 1%	{ Mod w/ C112(C112.1) R146,R147
R149	101 +	47 k	1 w	Fixed	Comp.	10%	304-473
R150	101 +	27 k	1 w	Fixed	Comp.	10%	304-273
R151	101 +	470 Ω	1/2 w	Fixed	Comp.	10%	302-471
R152	101 +	500 k	2 w	Var.	Comp.	20%	311-034
R153	101 +	150 k	1/2 w	Fixed	Comp.	10%	302-154
R154	101 +	470 k	1/2 w	Fixed	Comp.	10%	302-474
R155	101-2743 2744 +	33 k 33 k	1 w 2 w	Fixed Fixed	Comp. Comp.	10% 10%	Use 306-333 306-333
R156	101 +	3.3 k	1/2 w	Fixed	Comp.	10%	302-332
R157	101 +	470 k	1/2 w	Fixed	Comp.	10%	302-474
R158	101 +	3.3 meg	1/2 w	Fixed	Comp.	10%	302-335

\*R146 and R147 selected for ratio 47/68 plus or minus 2-1/2%.

Resistors(continued)

R159	101 +	10 k	2 w	Var.	WW	20%	311-015
R160	101 +	4.5 k	10 w	Fixed	WW	5%	308-021
R161	101-471 472 +	20 k 20 k	2 w 2 w	Var. Var.	WW WW	20% 2%	Use 312-003 <sup>3</sup> 312-003
R163	101 +	10 k	2 w	Var.	WW	20%	311-015
R164	101 +	1.75 meg	1/2 w	Fixed	Prec.	1%	309-019
R165	101 +	750 k	1/2 w	Fixed	Prec.	1%	309-010
R165.1	101-2585 2586 +	1 meg 100 k	1/2 w 1/2 w	Fixed Fixed	Comp. Comp.	10% 10%	Use 302-104 302-104
R166	101-999 1000-2525 2526 +	10 k 10.1 k 6.25 k	1/2 w 1/2 w 1/2 w	Fixed Fixed Fixed	Prec. Prec. Prec.	1% 1% 1%	{ Mod w/ R117 309-033
R167	101 +	45 k	1 w	Fixed	Prec.	1%	310-093
R168	101 +	47 k	1 w	Fixed	Comp.	10%	304-473
R169	101 +	500 k	2 w	Var.	Comp.	20%	311-034
R169.1	101 +	150 k	1/2 w	Fixed	Comp.	10%	302-154
R169.2	101 +	68 k	1/2 w	Fixed	Comp.	10%	302-683
R169.3	101 +	1 meg	1/2 w	Fixed	Comp.	10%	302-105
R170	101 +	1 meg	1/2 w	Fixed	Comp.	10%	302-105
R171	101 +	100 k	2 w	Var.	Comp.	20%	311-026
R172	101 +	150 Ω	1/2 w	Fixed	Comp.	10%	302-151
R173	101 +	150 Ω	1/2 w	Fixed	Comp.	10%	302-151
R174	101-287 288-2700 2701 +	120 k 100 k 110 k	1/2 w 1 w 1 w	Fixed Fixed Fixed	Comp. Comp. Comp.	10% 10% 5%*	{ Mod w/R175 R177, R178 312-515(Set 4)

<sup>3</sup>For instruments with older, hand-calibrated SWEEP dial, also order standard etched SWEEP dial, part number.....366-508.

\*R174/R177 and R175/R178 matched to ratio 11/10 +or-2-1/2%.



## Resistors(continued)

R175	101-287 288-2700 2701 +	120 k 100 k 110 k	1/2 w 1 w 1 w	Fixed Fixed Fixed	Comp. Comp. Comp.	10% 10% 5%*	} Mod w/R174 R177, R178 312-515(Set 4)	
R176	101 +	5 k	2 w	Var.	Comp.	20%		311-011
R177	101-2700 2701 +	100 k 100 k	2 w 1/2 w	Fixed Fixed	Comp. Comp.	10% 5%*		Mod w/R174, R175 R178(Set-4) 312-515
R177.1	101 +	100 k	1/2 w	Fixed	Comp.	10%	302-104	
R178	101-2700 2701 +	100 k 100 k	2 w 1/2 w	Fixed Fixed	Comp. Comp.	10% 5%*	Mod w/R174, R175, R177 312-515(Set 4)	
R178.1	101 +	100 k	1/2 w	Fixed	Comp.	10%	302-104	
R179	101 +	4.7 meg	2 w	Fixed	Comp.	10%	306-475	
R180	101 +	4.7 meg	2 w	Fixed	Comp.	10%	306-475	
R181	101 +	820 k	1/2 w	Fixed	Comp.	10%	302-824	
R182	101 +	820 k	1/2 w	Fixed	Comp.	10%	302-824	
R183	101 +	100 k	1 w	Fixed	Comp.	10%	304-104	
R184	101 +	47 k	1 w	Fixed	Comp.	10%	304-473	
R185	101 +	680 k	1/2 w	Fixed	Comp.	10%	302-684	
R185.1	X127 +	2.2 meg	1/2 w	Fixed	Comp.	10%	302-225	
R186	101-126 127 +	1 meg 1.5 meg	1/2 w 1/2 w	Fixed Fixed	Comp. Comp.	10% 10%	Mod w/R185.1 302-155	
R187	101 +	6.8 k	1 w	Fixed	Comp.	10%	304-682	
R188	101 +	5 k	2 w	Var.	WW	20%	311-012	
R189	101-125 126-2293 2294 +	47 k 47 k 39 k	1 w 2 w 2 w	Fixed Fixed Fixed	Comp. Comp. Comp.	10% 10% 10%	Use 306-393 Use 306-393 306-393	
R190	101 +	100 k	1/2 w	Fixed	Comp.	10%	302-104	
R191A	101 +	2 Ω	1/2 w	Fixed	Prec.	1%	309-058	

\*R174/R177 and R175/R178 matched to ratio 11/10 + or - 2-1/2%.

## Resistors(continued)

R191B	101 +	4 Ω	1/2 w	Fixed	Prec.	1%	309-060
R191C	101 +	14 Ω	1/2 w	Fixed	Prec.	1%	309-062
R191D	101 +	40 Ω	1/2 w	Fixed	Prec.	1%	309-066
R191E	101 +	142 Ω	1/2 w	Fixed	Prec.	1%	309-071
R191F	101 +	416 Ω	1/2 w	Fixed	Prec.	1%	309-079
R191G	101 +	1582 Ω	1/2 w	Fixed	Prec.	1%	309-029
R191H	101 +	525 k	1/2 w	Fixed	Prec.	1%	309-032
R191I(J)	101 +	13.23 k	1/2 w	Fixed	Prec.	1%	309-035
R192	101-471 472 +	20 k 20 k	2 w 2 w	Var. Var.	WW WW	-1,+10% 2%	Use 312-003 312-003
R192.1	101-471X	Selected	1/2 w	Fixed	Comp.	10%	Order by value
R301	101 +	22 k	1/2 w	Fixed	Comp.	10%	302-223
R302	101 +	50 Ω	2 w	Var.	WW	20%	311-055
R303	101 +	500 k	2 w	Var.	Comp.	20%	311-034
R304	101-2310 2311 +	4.7 meg 1 meg	1/2 w 1/2 w	Fixed Fixed	Comp. Comp.	10% 10%	302-475 302-105
R305	101-2310 2311 +	2 meg 1 meg	2 w 2 w	Var. Var.	Comp. Comp.	20% 20%	311-042 311-039
R306	101-2310 2311 +	1.5 meg 1 meg	1/2 w 1/2 w	Fixed Fixed	Comp. Comp.	10% 10%	302-155 302-105
R307	101-2146X Replaced by R352	100 k	1/2 w	Fixed	Comp.	10%	302-104
R308	101-2146X Replaced by R351	500 k	2 w	Var.	Comp.	20%	311-034
R309	101 +	1 meg	1/2 w	Fixed	Comp.	10%	302-105
R350	X2147 +	100 k	1/2 w	Fixed	Comp.	10%	302-104
R351	X2147 +	2 meg	2 w	Var.	Comp.	20%	311-042
R352	X2147 +	56 k	1/2 w	Fixed	Comp.	10%	302-563



**Switches**

SW101	101 +	2 wafer	5 position	rotary	TRIGGER SELECTOR	unwired	260-032
SW102	101 +	9 wafer	11 position	rotary	SWEEP RANGE	unwired wired	260-065 262-031
SW103	101 +	2 wafer	2 position	rotary	SWEEP MAGNIFIER	unwired	260-025
SW104	101 +	1 wafer	9 position	rotary	CAL RANGE	unwired wired	260-023 262-004
SW105	101 +	DPDT		toggle	CAL	unwired	260-068

**Vacuum Tubes**

V101	101 +	6J6	Delayed Trigger and Magnifier Selector	154-032
V102	101 +	6AU6	Delayed Trigger and Magnifier Shaper	154-022
V103	101 +	6AU6	Magnified Sweep Generator	154-022
V104	101 +	12AU7	Magnified Sweep and Delayed Trigger C.F.'s	154-041
V105	101 +	12AU7	Mag. Sweep Voltage Regulator and Clamp Diode	154-041
V106	101 +	12AU7	+Gate Amplifier and Blanking Gate Inverter	154-041
V107	101 +	6AU6	Blanking Oscillator	154-022
V108	101 +	6AU6	Trigger Amplifier	154-022
V109	101 +	6AU6	Trigger Amplifier	154-022
V110	101 +	6AU6	Trigger Amplitude Control	154-022
V111	101 +	6J6	Trigger Limiter and Clamp Diode	154-032
V112	101 +	6BH6	Phantastron Sweep Generator	154-026
V113	101 +	12AU7	Phantastron and Sweep Output C.F.	154-041
V114	101 +	12AT7	Sweep Amplifier	154-039
V115	101 +	12AU7	Calibrator Multivibrator	154-041
V116	101 +	12AU7	Calibrator Diode and Output C.F.	154-041
V301	101-2525 2526 +	5CP7A 5ABP7	(Curved face)CRT (Flat face)CRT	154-063 154-069
V302	101 +	6AL5	Blanking Bias Rectifier	154-016

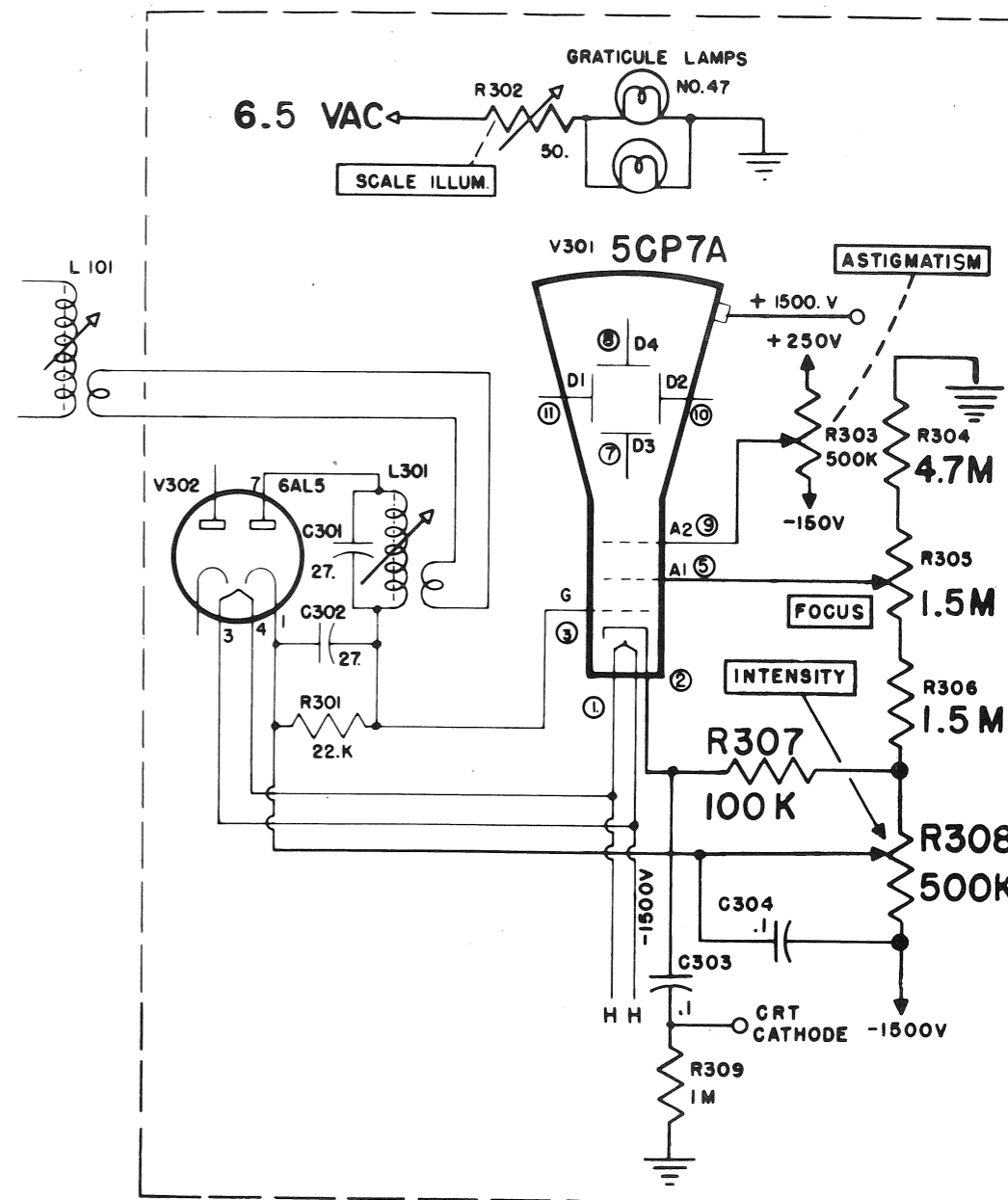

**CRT CIRCUIT FOR S/N 101-2146 ONLY.  
SEE SWEEP DIAGRAM FOR S/N 2147 UP.**





#### NOTE

Unless otherwise specified, all of the voltage readings were taken with a dc vacuum-tube voltmeter having an input resistance of 11 megohms. The waveforms shown were reproduced from actual photographs. There will be considerable variation between instruments because of normal manufacturing tolerances and vacuum-tube characteristics. Therefore, the significance of any discrepancies observed should be determined by referring to the circuit diagram.

All readings are in volts unless otherwise specified. Where two voltage readings are given, they represent the voltage as read by a voltmeter under two sets of conditions, and, as such, do not indicate the peak-to-peak excursion of voltage at the point.

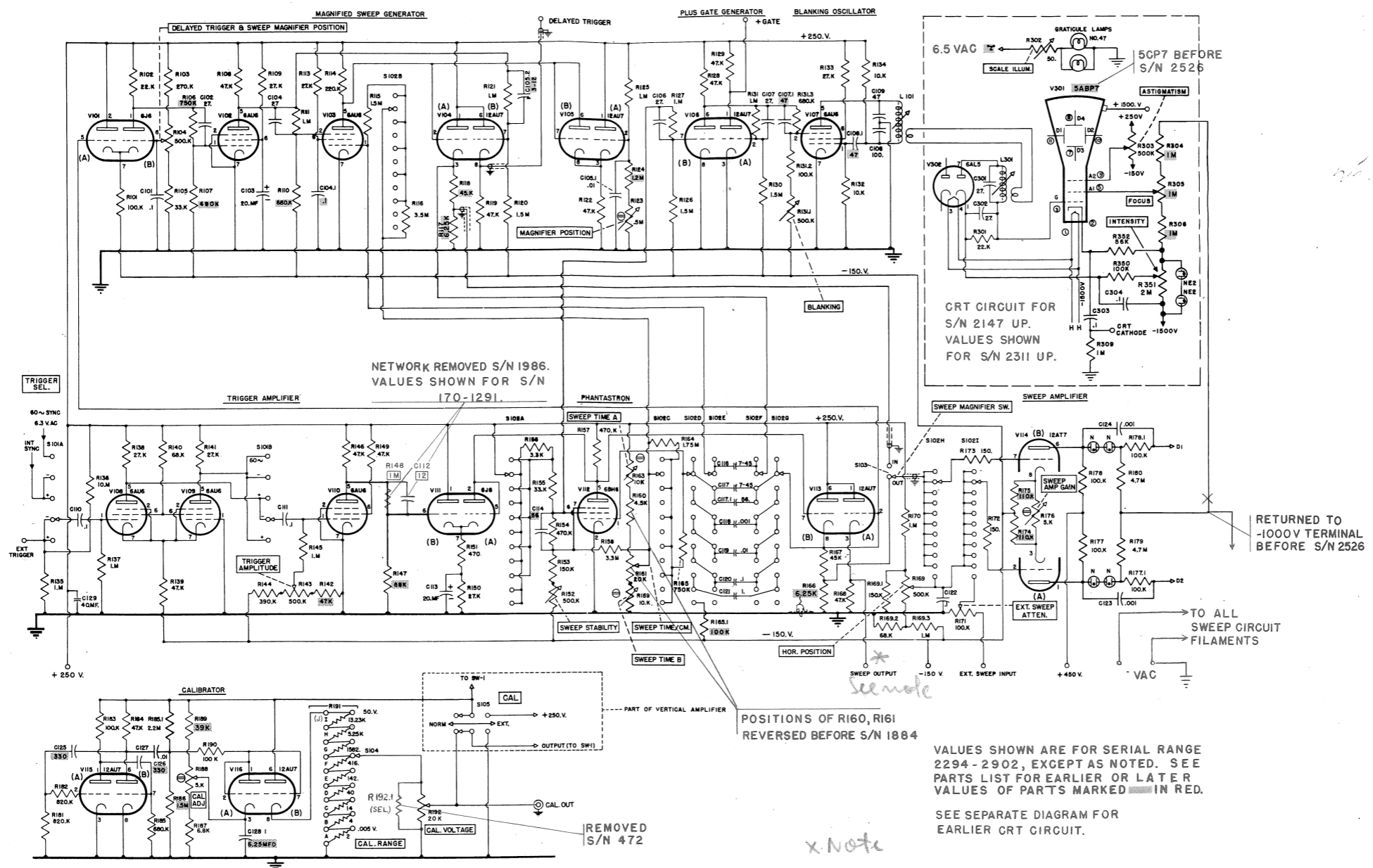

NETWORK REMOVED S/N 1986.  
VALUES SHOWN FOR S/N  
170-1291.

CRT CIRCUIT FOR  
S/N 2147 UP.  
VALUES SHOWN  
FOR S/N 2311 UP.

RETURNED TO  
-1000V TERMINAL  
BEFORE S/N 2526

POSITIONS OF R160, R161  
REVERSED BEFORE S/N 1884

VALUES SHOWN ARE FOR SERIAL RANGE  
2294 - 2902, EXCEPT AS NOTED. SEE  
PARTS LIST FOR EARLIER OR LATER  
VALUES OF PARTS MARKED ■ IN RED.

SEE SEPARATE DIAGRAM FOR  
EARLIER CRT CIRCUIT.

TYPE 512

x Note  
V113 SWEEP, CALIBRATOR, AND CRT

35100x 180K -150V  
47K sw. out purpose to start  
from zero

## VERTICAL AMPLIFIER

### ABBREVIATIONS

Cer	Ceramic	m	milli or 10 <sup>-3</sup>
Comp.	Composition	Ω	ohm
EMC	Electrolytic, metal cased	PBT	Paper, "Bathtub"
f	Farad	PMC	Paper, metal cased
GMV	Guaranteed minimum value	Poly.	Polystyrene
h	Henry	Prec.	Precision
k	Kilohm or 10 <sup>3</sup> ohms	PT	Paper Tubular
M/Cer.	Mica or Ceramic	v	Working volts DC
meg	Megohm or 10 <sup>6</sup> ohms	Var.	Variable
μ	Micro. or 10 <sup>-6</sup>	w	Watt
μ μ	Micromicro or 10 <sup>-12</sup>	WW	Wire-wound

### Special Notes and Symbols

+	and up.
†	Approximate serial number.
X000	Part first added at this serial number.
000X	Part removed after this serial number.
(Mod. w/)	Simple replacement not recommended. Modify to value for later instruments and change other listed parts to match.

							Capacitors	Order Parts by Number
C1	101-3438 3439 +	0.1 μf 0.1 μf	600 v 600 v	Fixed Fixed	PT PT	20% w/C2	285-528 295-048(Set) <sup>1</sup>	
C1.1	X331-2525 2526 +	.001 μf .01 μf	500 v 500 v	Fixed Fixed	Cer. Mica	GMV 20%	Mod. w/C2.1 283-002	
C2	101-3438 3439 +	0.1 μf 0.1 μf	600 v 600 v	Fixed Fixed	PT PT	20% w/C1	285-528 295-048(Set) <sup>1</sup>	
C2.1	X331-2525 2526 +	.001 μf .01 μf	500 v 500 v	Fixed Fixed	Cer. Mica	GMV 20%	Mod w/C1.1 283-002	
C3	101 +	5-20 μf*	500 v	Var.	Cer.		281-010	
C3.1	X313 +	8 μf	500 v	Fixed	Cer.	25%	281-503	
C4	101 +	5-20 μf*	500 v	Var.	Cer.		281-010	

<sup>1</sup> C1, C2 Matched plus or minus 1%

\*In some earlier instruments 4.5-25 μf



Capacitors (continued)

C4.1	X313 +	8 $\mu\text{f}$	500 v	Fixed	Cer.	25%	281-503
C5	101 +	7-45 $\mu\text{f}$	500 v	Var.	Cer.		281-012
C6	101 +	7-45 $\mu\text{f}$	500 v	Var.	Cer.		281-012
C7	101 +	0.1 $\mu\text{f}$	600 v	Fixed	PT	20%	285-528
C8	101 +	0.1 $\mu\text{f}$	600 v	Fixed	PT	20%	285-528
C9 <sup>2</sup>	101-2227 †	5-20 $\mu\text{f}$ *	500 v	Var.	Cer.		281-010
	2228 † +	3-12 $\mu\text{f}$	500 v	Var.	Cer.		281-007
C11	101 +	3-12 $\mu\text{f}$ **	500 v	Var.	Cer.		281-007
C12	101 +	3-12 $\mu\text{f}$ **	500 v	Var.	Cer.		281-007
C13	101-129	1.5-7 $\mu\text{f}$	500 v	Var.	Cer.		Mod w/C14
	130 +	3-12 $\mu\text{f}$ ***	500 v	Var.	Cer.		281-007
C14	101-129	1.5-7 $\mu\text{f}$	500 v	Var.	Cer.		Mod w/C13
	130 +	3-12 $\mu\text{f}$ ***	500 v	Var.	Cer.		281-007
C15	101 +	3-12 $\mu\text{f}$ **	500 v	Var.	Cer.		281-007
C16	101 +	3-12 $\mu\text{f}$ **	500 v	Var.	Cer.		281-007
C17	101 +	1.5-7 $\mu\text{f}$	500 v	Var.	Cer.		281-005
C18	101 +	1.5-7 $\mu\text{f}$	500 v	Var.	Cer.		281-005
C21	101 +	27 $\mu\text{f}$	400 v	Fixed	M/or Cer.	20%	281-513
C22	101 +	27 $\mu\text{f}$	400 v	Fixed	M/or Cer.		281-513
C23	101 +	3-12 $\mu\text{f}$ **	500 v	Var.	Cer.		281-007
C24	101 +	3-12 $\mu\text{f}$ **	500 v	Var.	Cer.		281-007
C25	101 +	1.5-7 $\mu\text{f}$	500 v	Var.	Cer.		281-005
C26	101 +	1.5-7 $\mu\text{f}$	500 v	Var.	Cer.		281-005
C27	101 +	100 $\mu\text{f}$	400 v	Fixed	Mica	10%	283-505

<sup>2</sup>In P510 probe.

\*In some earlier instruments 4.5  $\mu\text{f}$ .

\*\*In some earlier instruments 4-13  $\mu\text{f}$ .

\*\*\*In some earlier instruments 2.5-13  $\mu\text{f}$ .

Capacitors (continued)

C28	101 +	100 $\mu\text{f}$	400 v	Fixed	Mica	10%	283-505
C31	101 +	3-12 $\mu\text{f}$	500 v	Var.	Cer.		281-007
C32	101 +	3-12 $\mu\text{f}$	500 v	Var.	Cer.		281-007
C33	101 +	1.5-7 $\mu\text{f}$	500 v	Var.	Cer.		281-005
C34	101 +	1.5-7 $\mu\text{f}$	500 v	Var.	Cer.		281-005
C35	101-582	300 $\mu\text{f}$	400 v	Fixed	Mica	10%	Mod w/C36
	583 +	330 $\mu\text{f}$	400 v	Fixed	Mica	10%	283-518
C36	101-582	300 $\mu\text{f}$	400 v	Fixed	Mica	10%	Mod w/C35
	583 +	330 $\mu\text{f}$	400 v	Fixed	Mica	10%	283-518
C37	101 +	1.5-7 $\mu\text{f}$	500 v	Var.	Cer.		281-005
C38	101 +	1.5-7 $\mu\text{f}$	500 v	Var.	Cer.		281-005
C39	101-2801	.01 $\mu\text{f}$	400 v	Fixed	PT	20%	285-510
	2802 +	.01 $\mu\text{f}$	500 v	Fixed	Cer.	GMV	283-002
C40	101-2801	.01 $\mu\text{f}$	400 v	Fixed	PT	20%	285-510
	2802 +	.01 $\mu\text{f}$	500 v	Fixed	Cer.	GMV	283-002
C41	101 +	.01 $\mu\text{f}$	400 v	Fixed	PT	20%	285-510
C42	101 +	.01 $\mu\text{f}$	400 v	Fixed	PT	20%	285-510
C43	101 +	.01 $\mu\text{f}$	400 v	Fixed	PT	20%	285-510
C44	101 +	.01 $\mu\text{f}$	400 v	Fixed	PT	20%	285-510
C45	101-562	.01 $\mu\text{f}$	400 v	Fixed	PT	20%	Use 285-511
	563 +	.01 $\mu\text{f}$	600 v	Fixed	PT	20%	285-511
C93	X2526-3432X	.022 $\mu\text{f}$	400 v	Fixed	PT	20%	285-515

Inductors

L1	101-1782	90-140 $\mu\text{h}$	Var.	Use 114-029
	1783-2377	73-100 $\mu\text{h}$	Var.	
	2378 +	99-185 $\mu\text{h}$	Var.	
L3	101-2087	195-310 $\mu\text{h}$	Var.	Mod w/L4
	2088-2525	280-420 $\mu\text{h}$	Var.	
	2526 +	320-500 $\mu\text{h}$	Var.	



CRT

Inductors (continued)

L4	101-2087 2088-2525 2526 +	195-310 $\mu$ h 280-420 $\mu$ h 320-500 $\mu$ h	Var. Var. Var.	Mod w/L3 Mod w/L3 114-016
L5	101-2146 † 2147 †-2525 2526 +	155-245 $\mu$ h 180-360 $\mu$ h 120-195 $\mu$ h	Var. Var. Var.	Mod w/L6 Mod w/L6 114-002
L6	101-2146 † 2147 †-2525 2526 +	155-245 $\mu$ h 180-360 $\mu$ h 120-195 $\mu$ h	Var. Var. Var.	Mod w/L5 Mod w/L5 114-002

Resistors

R1	101 +	1 meg	1/2 w	Fixed	Prec.	1%	309-014
R1.1	X331 +	1 meg	1/2 w	Fixed	Comp.	10%	302-105
R2	101 +	1 meg	1/2 w	Fixed	Prec.	1%	309-014
R2.1	X331 +	1 meg	1/2 w	Fixed	Comp.	10%	302-105
R3	101-2087 2088-2525 2526 +	56 k 47 k 68 k	1 w 1 w 1 w	Fixed Fixed Fixed	Comp. Comp. Comp.	10% 10% 10%	Use 304-473 304-473 304-683
R4	101 +	500 $\Omega$	2 w	Var.	Comp.	20%	311-005
R5	101 +	330 $\Omega$	1/2 w	Fixed	Comp.	10%	302-331
R6 <sup>1</sup>	101 +	9 meg	1 w	Fixed	Prec.	1%	310-106
R7	101-169 170-2525 2526-3093 3094 +	4.7 k $\Omega$ 4.7 k 5.6 k 5.6 k	1/2 w 1/2 w 1 w 1/2 w	Fixed Fixed Fixed Fixed	Comp. Comp. Comp. Prec.	10% 2% 2% 1%	Mod w/R8 Mod w/R8 Mod w/R8 309-132
R8	101-169 170-2525 2526-3093 3094 +	4.7 k 4.7 k 5.6 k 5.6 k	1/2 w 1/2 w 1 w 1/2 w	Fixed Fixed Fixed Fixed	Comp. Comp. Comp. Prec.	10% 2% 2% 1%	Mod w/R7 Mod w/R7 Mod w/R7 309-132
R9	101 +	100 $\Omega$	1/2 w	Fixed	Comp.	10%	302-101
R10	101 +	100 $\Omega$	1/2 w	Fixed	Comp.	10%	302-101
R11	101 +	4.7 k	1 w	Fixed	Comp.	10%	304-472

<sup>1</sup> In P510 probe.

Resistors (continued)

R12	101 +	4.7 k	1 w	Fixed	Comp.	10%	304-472
R13	101 +	5 k	2 w	Var.	Comp.	20%	311-011
R14	101 +	10 k	10 w	Fixed	WW	5%	308-023
R15	101 +	500 $\Omega$	2 w	Var.	Comp.	20%	311-005
R16	101 +	220 $\Omega$	1/2 w	Fixed	Comp.	10%	302-221
R17	101 +	500 $\Omega$	2 w	Var.	Comp.	20%	311-005
R18	101 +	820 $\Omega$	1/2 w	Fixed	Comp.	10%	302-821
R19	101 +	220 k	1/2 w	Fixed	Comp.	10%	302-224
R19.1	X189 +	100 k	1/2 w	Fixed	Comp.	10%	302-104
R20	101 +	100 k	2 w	Var.	Comp.	20%	311-026
R20.1	X189 +	100 k	2 w	Var.	Comp.	20%	311-026
R21	101-2525 2526 +	100 k 220 k	1/2 w 1/2 w	Fixed Fixed	Comp. Comp.	10% 10%	302-104 302-224
R21.1	X189 +	100 k	1/2 w	Fixed	Comp.	10%	302-104
R23	101-169 170-2087 2088-2525 2526 +	4.7 k 4.7 k 5.6 k 5.6 k	1/2 w 1/2 w 1/2 w 1 w	Fixed Fixed Fixed Fixed	Comp. Comp. Comp. Comp.	10% 2% 2% 2%	Mod w/R24 Mod w/R24 Mod w/R24 312-532
R24	101-169 170-2087 2088-2525 2526 +	4.7 k 4.7 k 5.6 k 5.6 k	1/2 w 1/2 w 1/2 w 1 w	Fixed Fixed Fixed Fixed	Comp. Comp. Comp. Comp.	10% 2% 2% 2%	Mod w/R23 Mod w/R23 Mod w/R23 312-532
R25	101 +	120 k	1/2 w	Fixed	Prec.	1%	309-047
R26	101 +	120 k	1/2 w	Fixed	Prec.	1%	309-047
R27	101 +	150 k	1/2 w	Fixed	Prec.	1%	309-049
R28	101 +	150 k	1/2 w	Fixed	Prec.	1%	309-049
R29	101 +	666.6 k	1/2 w	Fixed	Prec.	1%	309-007
R30	101 +	666.6 k	1/2 w	Fixed	Prec.	1%	309-007
R31	101 +	500 k	1/2 w	Fixed	Prec.	1%	309-003



## Resistors (continued)

R32	101 +	500 k	1/2 w	Fixed	Prec.	1%	309-003
R33	101-1239 1240 +	900 k 900 k	1/2 w 1 w	Fixed Fixed	Prec. Prec.	1% 1%	Use 310-097 310-097
R34	101-1239 1240 +	900 k 900 k	1/2 w 1 w	Fixed Fixed	Prec. Prec.	1% 1%	Use 310-097 310-097
R35	101 +	111 k	1/2 w	Fixed	Prec.	1%	309-046
R36	101 +	111 k	1/2 w	Fixed	Prec.	1%	309-046
R37	101-1239 1240 +	966.7 k 966.7 k	1/2 w 1 w	Fixed Fixed	Prec. Prec.	1% 1%	Use 310-099 310-099
R38	101-1239 1240 +	966.7 k 966.7 k	1/2 w 1 w	Fixed Fixed	Prec. Prec.	1% 1%	Use 310-099 310-099
R39	101 +	34.5 k	1/2 w	Fixed	Prec.	1%	309-038
R40	101 +	34.5 k	1/2 w	Fixed	Prec.	1%	309-038
R41	101 +	990 k	1 w	Fixed	Prec.	1%	310-098
R42	101 +	990 k	1 w	Fixed	Prec.	1%	310-098
R43	101 +	10.1 k	1/2 w	Fixed	Prec.	1%	309-034
R44	101 +	10.1 k	1/2 w	Fixed	Prec.	1%	309-034
R45	101 +	1 k	1/2 w	Fixed	Comp.	10%	302-102
R46	101 +	1 k	1/2 w	Fixed	Comp.	10%	302-102
R47	101 +	1 meg	1/2 w	Fixed	Prec.	1%	309-014
R48	101 +	1 meg	1/2 w	Fixed	Prec.	1%	309-014
R49	101 +	56 k	1 w	Fixed	Comp.	10%	304-563
R50	101 +	56 k	1 w	Fixed	Comp.	10%	304-563
R51	101-119 120 +	5 k 20 k	2 w 2 w	Var. Var.	Comp. Comp.	20% 20%	Use 311-018 311-018
R52	101-329 330-361 362 +	820 Ω 1.2 k 820 Ω	1/2 w 1/2 w 1/2 w	Fixed Fixed Fixed	Comp. Comp. Comp.	10% 10% 10%	302-821 Mod w/R53+54 302-821

## Resistors (continued)

R53+54	101-329 330-361 362 +	2x1.0 k 2x1.5 k 2x1 k	2 w ea. 2 w ea. 2 w ea.	Dual Var. Dual Var. Dual Var.	Comp. Comp. Comp.	20% 20% 20%	311-007 Mod w/R52 311-007
R55	101-150 151 +	9 k(27k/3) 10 k	3x1 w 10 w	Fixed Fixed	Comp. WW	10% 5%	Use 308-023 308-023
R56	101 +	500 Ω	2 w	Var.	Comp.	20%	311-005
R57	101-149 150 +	82 Ω 100 Ω	1/2 w 1/2 w	Fixed Fixed	Comp. Comp.	10% 10%	Use 302-101 302-101
R59	101-149 150-169 170-2146 † 2147 † +	1.5 k 1.8 k 1.8 k 1.8 k	1/2 w 1/2 w 1/2 w 1/2 w	Fixed Fixed Fixed Fixed	Comp. Comp. Comp. Comp.	10% 10% 2% 5%*	Mod w/R60 Mod w/R60 Mod w/R60 312-531(Pr.)
R59.1	101-300 301 +	330 Ω 390 Ω	1/2 w 1/2 w	Fixed Fixed	Comp. Comp.	10% 10%	Use 302-391 302-391
R60	101-149 150-2146 † 2147 † +	1.8 k 2.2 k 2.2 k	1/2 w 1/2 w 1/2 w	Fixed Fixed Fixed	Comp. Comp. Comp.	10% 2% 5%*	Mod w/R59 Mod w/R59 312-531(Pr.)
R61	101 +	100 Ω	1/2 w	Fixed	Comp.	10%	302-101
R61.1	X449 +	68 k	1/2 w	Fixed	Comp.	10%	302-683
R61.2	X449 +	100 k	2 w	Var.	Comp.	20%	311-026
R61.3	X449 +	68 k	1/2 w	Fixed	Comp.	10%	302-683
R62	101 +	100 Ω	1/2 w	Fixed	Comp.	10%	302-101
R63	101-2525X	825 Ω (3.3k/4)	4x1 w	Fixed	Comp.	10%	304-332 (Ea.)
Replaced by R90, R91, R94, R95							
R64	101 +	6.6 k	2x1 w (2x3.3k)	Fixed	Comp.	10%	304-332(Ea.)
R65	101-2801 2802 +	100 Ω 47 Ω	1/2 w 1/2 w	Fixed Fixed	Comp. Comp.	10% 10%	Use 302-470 302-470
R66	101-2801 2802 +	100 Ω 47 Ω	1/2 w 1/2 w	Fixed Fixed	Comp. Comp.	10% 10%	Use 302-470 302-470

\*R59, R60 paired for ratio of 2.2/1.8 plus or minus 1%.



## Resistors (continued)

R67	101-2801	4 k(4x1k)	8 w(4x2w)	Fixed	Comp.	10%**	Use 310-508
	2802-3422	4 k	5 w	Fixed	WW	2%	Use 310-508
	3423 +	4 k	5 w	Fixed	Mica Pl.	1%	310-508
R68	101-2801	4 k(4x1k)	8 w(4x2w)	Fixed	Comp.	10%**	Use 310-508
	2802-3422	4 k	5 w	Fixed	WW	2%	Use 310-508
	3423 +	4 k	5 w	Fixed	Mica Pl.	1%	310-508
R69	101-448 †	100 k	1/2 w	Fixed	Comp.	10%	Mod w/R70
	449 † +	220 k	1/2 w	Fixed	Comp.	10%	302-224
R70	101-448 †	100 k	1/2 w	Fixed	Comp.	10%	Mod w/R69
	449 † +	220 k	1/2 w	Fixed	Comp.	10%	302-224
R71	101 +	100 k	1 w	Fixed	Comp.	10%	304-104
R72	101 +	10 k	1/2 w	Fixed	Comp.	10%	302-103
R73	101-169	470 k	1/2 w	Fixed	Comp.	10%	Use 312-518
	170 +	470 k	1/2 w	Fixed	Comp.	2%	312-518
R74	101-169	5.6 meg	1/2 w	Fixed	Comp.	10%	Use 2%
	170-2525	5.6 meg	1/2 w	Fixed	Comp.	2%	Order by value
	2526 +	1.2 meg	1/2 w	Fixed	Comp.	2%	312-526
R75	101-169	1 meg	1/2 w	Fixed	Comp.	10%	Use 312-523
	170 +	1 meg	1/2 w	Fixed	Comp.	2%	312-523
R76	101-169	680 k	1/2 w	Fixed	Comp.	10%	Use 2%
	170-2525	680 k	1/2 w	Fixed	Comp.	2%	Order by value
	2526 +	560 k	1/2 w	Fixed	Comp.	2%	312-522
R77	101 +	8.2 k	2 w	Fixed	Comp.	10%	306-822
R78	101 +	400 Ω	20 w	Fixed	WW	5%	308-029
R79	101-169	1 meg	1/2 w	Fixed	Comp.	10%	Use 312-523
	170 +	1 meg	1/2 w	Fixed	Comp.	2%	312-523
R80	101-169	1 meg	1/2 w	Fixed	Comp.	10%	Use 312-523
	170 +	1 meg	1/2 w	Fixed	Comp.	2%	312-523
R81	101-169	560 k	1/2 w	Fixed	Comp.	10%	Use 312-522
	170 +	560 k	1/2 w	Fixed	Comp.	2%	312-522
R82	101-169	2.2 meg	1/2 w	Fixed	Comp.	10%	Use 312-527
	170 +	2.2 meg	1/2 w	Fixed	Comp.	2%	312-527

\*\*Starting at approximately Serial No. 2147, sets of resistors for R67 and R68 are selected to total 4k, plus or minus 2%.

## Resistors (continued)

R83	101 +	220 k	1/2 w	Fixed	Comp.	10%	302-224
R84	101 +	5.6 meg	1/2 w	Fixed	Comp.	10%	302-565
R85	X2526 +	8.2 k	1 w	Fixed	Comp.	10%	304-822
R90*	X2526 +	3.3 k	1 w	Fixed	Comp.	10%	304-332
R91*	X2526 +	3.3 k	1 w	Fixed	Comp.	10%	304-332
R92	X2526-2889	150 Ω	1/2 w	Fixed	Comp.	10%	Mod w/R93
		2890 +	120 Ω	1/2 w	Fixed	Comp.	10%
R93	X2526-2889	10 Ω	1/2 w	Fixed	Comp.	10%	Mod w/R92
		2890 +	15 Ω	1/2 w	Fixed	Comp.	10%
R94***	X2526 +	3.3 k	1 w	Fixed	Comp.	10%	304-332
R95***	X2526 +	3.3 k	1 w	Fixed	Comp.	10%	304-332
R97	X2890 +	15 k	1/2 w	Fixed	Comp.	10%	302-153
R98	X2890 +	15 k	1/2 w	Fixed	Comp.	10%	302-153

## Vacuum Tubes

V1	101-2525 2526 +	6AK6 5879	Vertical Preamp Input	} Order 5879 Mod Kit 1 Matched Pair, 157-014
			Vertical Preamp Input	
V2	101-2525 2526 +	6AK6 5879	Vertical Preamp Input	} Order 5879 Mod Kit 1 Matched Pair, 157-014
			Vertical Preamp Input	
V3	101 +	12AU6	Vertical Preamp Output	} Matched Pair, 157-012
			Vertical Preamp Output	
V4	101 +	12AU6	Vertical Preamp Output	} Matched Pair, 157-012
			Vertical Preamp Output	
V5	101 +	12AU6	Vertical Gain Control C.F.	} Matched Pair, 157-012
			Vertical Gain Control C.F.	
V6	101 +	12AU6	Vertical Gain Control C.F.	} Matched Pair, 157-012
			Vertical Gain Control C.F.	
V7	101 +	12AU6	Vertical Main Amplifier Input	} Matched Pair, 157-012
			Vertical Main Amplifier Input	
V8	101 +	12AU6	Vertical Main Amplifier Input	} Matched Pair, 157-012
			Vertical Main Amplifier Input	

\*Before S/N 2526, R90, R91, R94 and R95 were all in parallel, identified as R63.  
 1 Kit K-512-606-1 for instruments without shock-mounted preamp chassis 040-030.  
 Kit K512-606-2 for instruments with shock-mounted preamp chassis. 040-031.



Vacuum Tubes (continued)

V9	101 +	6AG7	Vertical Main Amplifier Output	154-012
V10	101 +	6AG7	Vertical Main Amplifier Output	154-012
V11	101 +	12AU7	Cathode Follower	154-041
V12	101 +	12AU7	Cathode Follower	154-041
V13	101 +	6AU6	Marker Input Amplifier	154-022

Switches

SW1	101 +	2 wafer	4 position	rotary	VERTICAL INPUT	unwired	260-062
SW2	101 +	2 wafer	2 position	rotary	AC-DC	wired unwired	262-029 260-063
SW3	101 +	9 wafer	8 position	rotary	VERT. DEFL. SENS.	wired unwired	262-030 260-058

NOTE

Unless otherwise specified, all of the voltage readings were taken with a dc vacuum-tube voltmeter having an input resistance of 11 megohms. The waveforms shown were reproduced from actual photographs. There will be considerable variation between instruments because of normal manufacturing tolerances and vacuum-tube characteristics. Therefore, the significance of any discrepancies observed should be determined by referring to the circuit diagram.

All readings are in volts unless otherwise specified. Where two voltage readings are given, they represent the voltage as read by a voltmeter under two sets of conditions, and, as such, do not indicate the peak-to-peak excursion of voltage at the point.





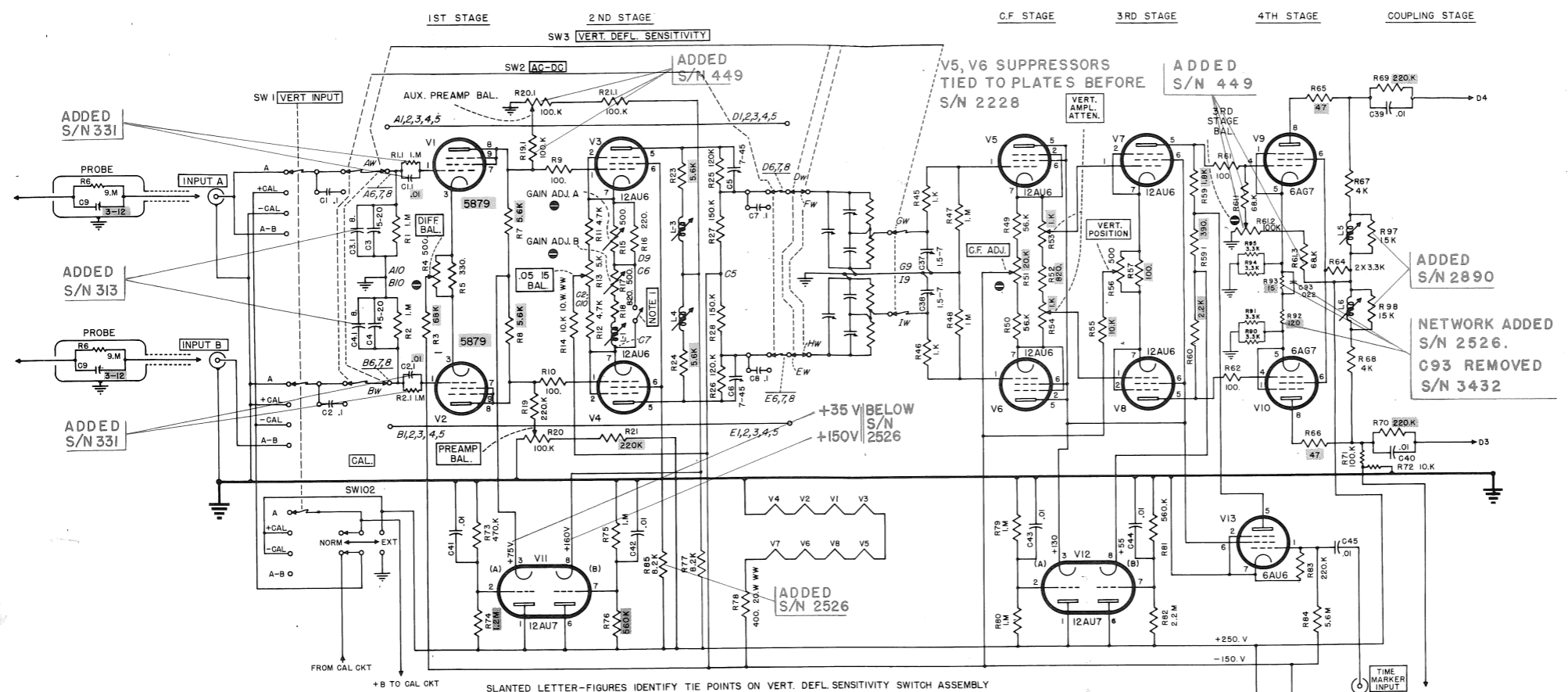

VERTICAL

(SW3 SWITCH DETAIL)

INPUT-OUTPUT RATIO →	1 TO 1	3 TO 1	10 TO 1	30 TO 1	100 TO 1
SWITCH POSITION USED →	5, 8	4, 6, 7	3	2	1
VERT. DEFL. SENS. SW POSITION	FS	F4, 6, 7	F3, 9	F2	F1
NOMINAL SENSITIVITY	50. V	16.7	10.0	3.33	1.0
1.	15.	5.0	1.5	0.5	0.15
2.	5.	1.67	0.5	0.167	0.05
3.	1.5	0.5	0.15	0.05	0.015
4.	.5	0.167	0.05	0.0167	0.005
5.	.15	0.05	0.015	0.005	0.0015
6.	.05	0.0167	0.005	0.00167	0.0005
7.	.015	0.005	0.0015	0.0005	0.00015
8.	.005	0.00167	0.0005	0.000167	0.00005

NOTE: 1 THIS SWITCH IS CLOSED EXCEPT IN POSITION 6 OF SW3.

VALUES SHOWN ARE FOR SERIAL RANGE 2890 UP. SEE PARTS LIST FOR EARLIER VALUES OF PARTS MARKED **B** IN RED.

PIN CONNECTIONS FOR V1 & V2 BELOW S/N 2526 (TYPE 6AK6)

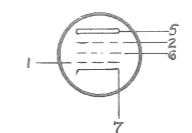

1-4-55  
VERTICAL AMPLIFIER  
7-7-58

## POWER SUPPLY

### ABBREVIATIONS

Cer	Ceramic	m	milli or 10 <sup>-3</sup>
Comp.	Composition	Ω	ohm
EMC	Electrolytic, metal cased	PBT	Paper, "Bathtub"
f	Farad	PMC	Paper, metal cased
GMV	Guaranteed minimum value	Poly.	Polystyrene
h	Henry	Prec.	Precision
k	Kilohm or 10 <sup>3</sup> ohms	PT	Paper Tubular
M/Cer.	Mica or Ceramic	v	Working volts DC
meg	Megohm or 10 <sup>6</sup> ohms	Var.	Variable
μ	Micro. or 10 <sup>-6</sup>	w	Watt
μ μ	Micromicro or 10 <sup>-12</sup>	WW	Wire-wound

### Special Notes and Symbols

+	and up.
†	Approximate serial number.
X000	Part first added at this serial number.
000X	Part removed after this serial number.
(Mod. w/)	Simple replacement not recommended. Modify to value for later instruments and change other listed parts to match.

							Order Parts by Number
Capacitors							
C207	101 +	40 μf (2x20 μf)	450 v	Fixed	EMC -20+50%		290-036
C208	101 +	.01 μf	400 v	Fixed	PT 20%		285-510
C209	101 +	80 μf (2-2x20 μf)	450 v	Fixed	EMC -20+50%		290-037(Ea.)
C210	101 +	.01 μf	400 v	Fixed	PT 20%		285-510
C211	101 +	80 μf (2-2x20 μf)	450 v	Fixed	EMC -20+50%		290-036(Ea.)
C212	101 +	.01 μf	400 v	Fixed	PT 20%		285-510
C213	101 +	.01 μf	400 v	Fixed	PT 20%		285-510
Resistors							
R206	101 +	270 k	1/2 w	Fixed	Comp. 10%		302-274
R207	101 +	100 k	1/2 w	Fixed	Comp. 10%		302-104



## Resistors (continued)

R208	101 +	2 meg	1/2 w	Fixed	Prec.	1%	309-023
R209	101 +	1.11 meg	1/2 w	Fixed	Prec.	1%	309-015
R210	101-2311X	1 meg	1 w	Fixed	Comp.	10%	304-105
R211	101 +	220 k	1 w	Fixed	Comp.	10%	304-224
R212	101 +	1 meg	1/2 w	Fixed	Comp.	10%	302-105
R213	101 +	1 k	25 w	Fixed	WW	5%	308-038
R214	101-2675 2676 +	10 k 33 k	1 w 1/2 w	Fixed Fixed	Comp. Comp.	10% 10%	304-103 302-333
R215	101-2675 2676 +	47 k 270 k	2 w 1/2 w	Fixed Fixed	Comp. Comp.	10% 10%	306-473 302-274
R216	101 +	600 k	1/2 w	Fixed	Prec.	1%	309-004
R217	101 +	1 meg	1/2 w	Fixed	Prec.	1%	309-014
R218	101-2675 2676 +	220 k 39 k	1 w 1/2 w	Fixed Fixed	Comp. Comp.	10% 10%	304-224 302-393
R219	101 +	1 meg	1/2 w	Fixed	Comp.	10%	302-105
R220	101 +	1 k	25 w	Fixed	WW	5%	308-038
R221	101-2675 2676 +	33 k 27 k	1/2 w 1/2 w	Fixed Fixed	Comp. Comp.	10% 10%	302-333 302-273
R222	101-2675 2676 +	1 k 18 k	1/2 w 1/2 w	Fixed Fixed	Comp. Comp.	10% 10%	302-102 302-183
R223	101-2675 2676 +	470 k 1 meg	1/2 w 1/2 w	Fixed Fixed	Comp. Comp.	10% 10%	302-474 302-105
R224	101-483 484 +	68 k 56 k	1/2 w 1/2 w	Fixed Fixed	Comp. Comp.	5% 5%	301-683 312-513
R225	101 +	10 k	2 w	Var.	WW	20%	311-015
R226	101-483 484 +	56 k 47 k	1/2 w 1/2 w	Fied Fixed	Comp. Comp.	5% 5%	312-513 301-473
R227	2676 +	27 k	1/2 w	Fixed	Comp.	10%	302-273



## Vacuum Tubes

V204	101 +	6X4	Sweep Power Supply Rectifier	154-035
V205	101 +	12AU7	Sweep Power Supply Regulator	154-041
V206	101 +	6AS7	Voltage Regulator Series Tube	154-020
V207	101 +	6W4	Low Voltage Rectifier	154-034
V208	101 +	6W4	Low Voltage Rectifier	154-034
V209	101 +	6AU6	Voltage Regulator Amplifier	154-022
V210	101 +	6W4	Low Voltage Rectifier	154-034
V211	101 +	6W4	Low Voltage Rectifier	154-034
V212	101 +	6AU6	Voltage Regulator Amplifier	154-022
V213	101 +	5651	Voltage Reference Tube	154-052

## Switch

SW201	SPST	Toggle	POWER	260-066
-------	------	--------	-------	---------

## Transformers

T201	Plate and Heater Supply	Type T512-PC1*		120-022
	Primary:	117/234 v AC	50/60 cycle	
	Secondaries:	215-0-215 v	210 ma	
		290-0-290 v	165 ma	
		260 v	10 ma	
		6.5 v	11 a	
		6.5 v	2.4 a	
		6.5 v	2.4 a	
		6.5 v	0.9 a	
		6.5 v	0.9 a insulated 1500 v DC	

\*Direct replacement for T512PA and T512PB, now obsolete.

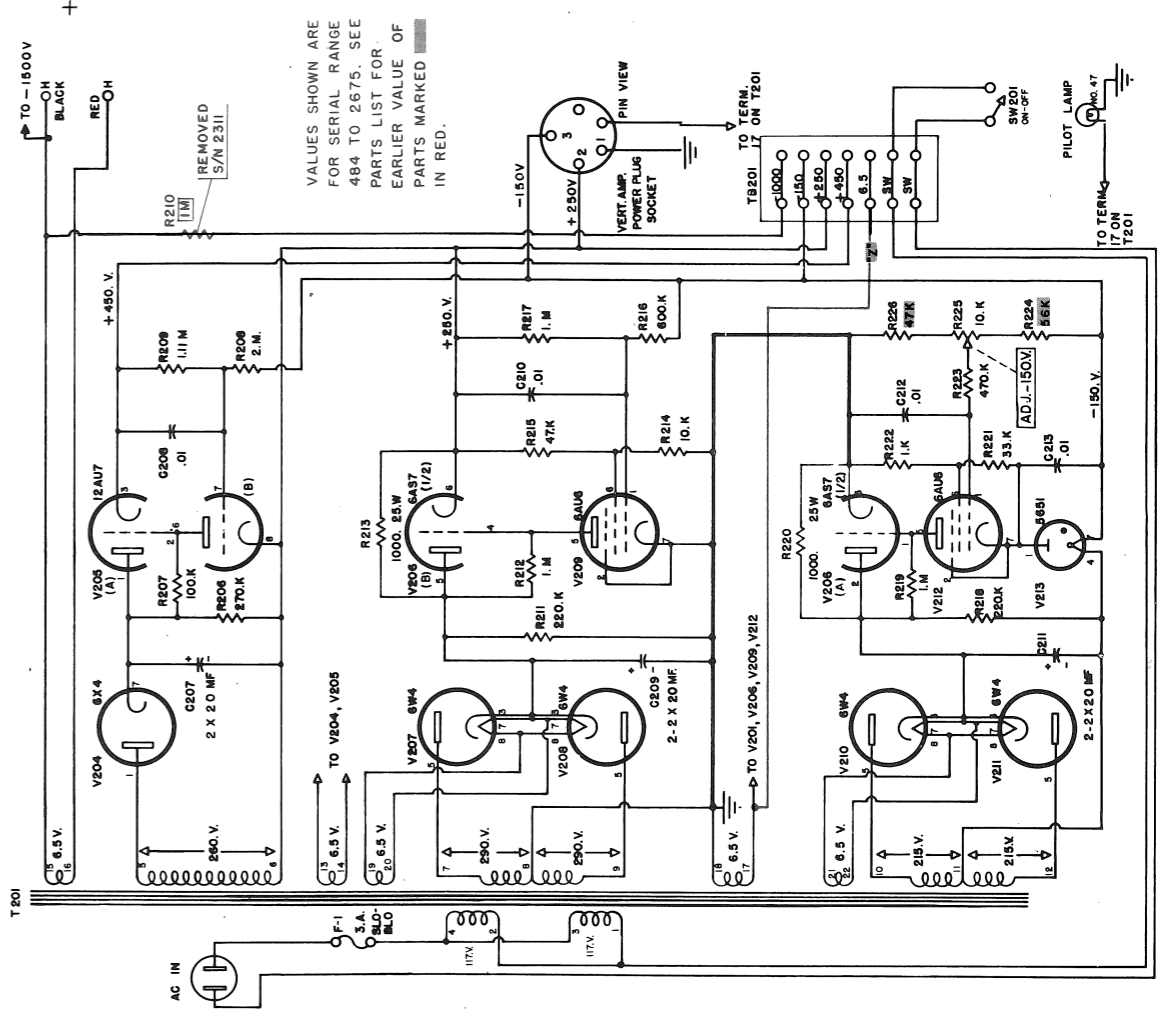

VALUES SHOWN ARE FOR SERIAL RANGE 484 TO 2675. SEE PARTS LIST FOR EARLIER VALUE OF PARTS MARKED IN RED.

TYPE 512 OSCILLOSCOPE  
+ POWER SUPPLY

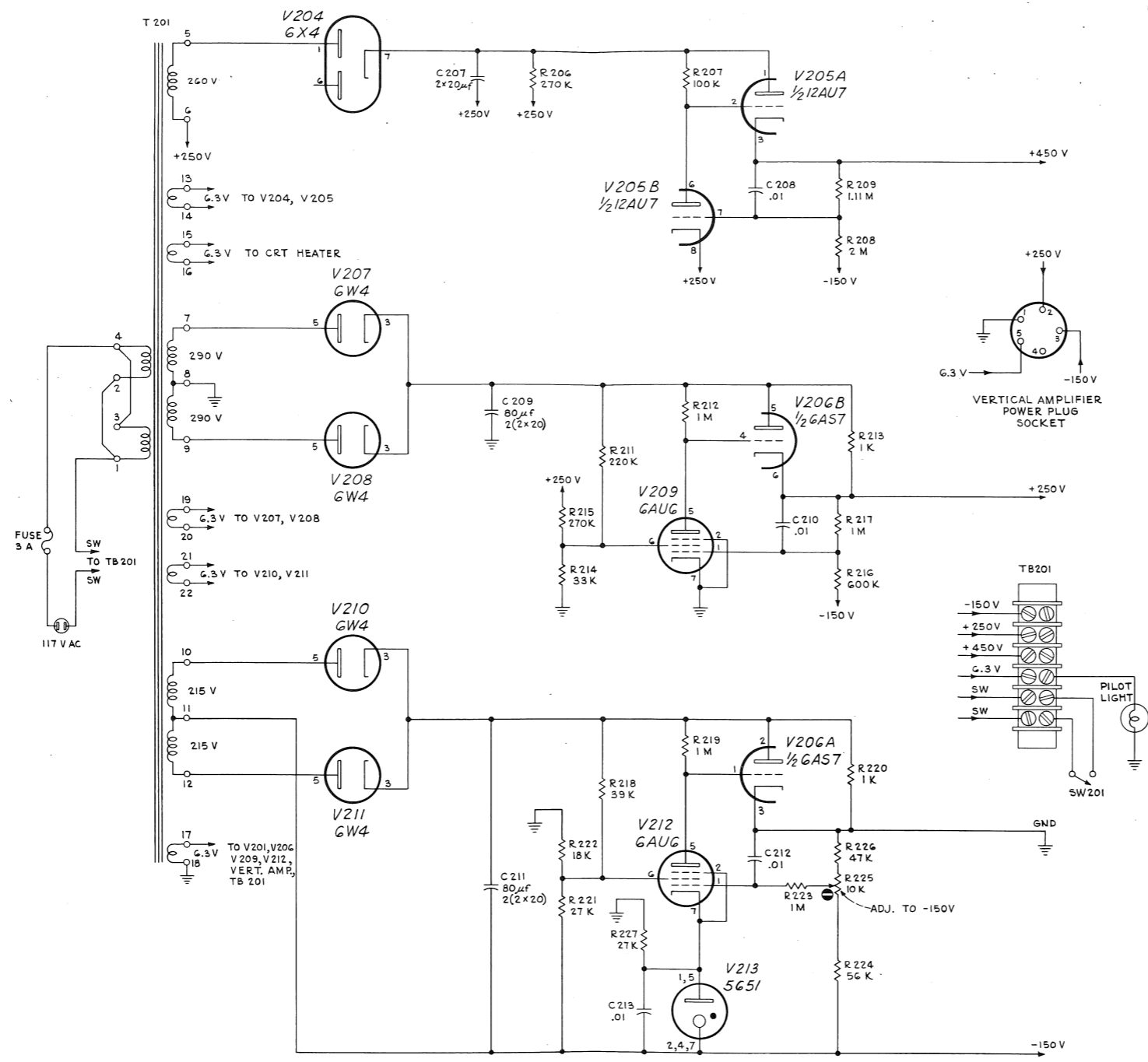

TYPE 512 CATHODE-RAY OSCILLOSCOPE

A

POWER SUPPLY  
S/N 2676 UP

POWER SUPPLY

## H. V. SUPPLY

### ABBREVIATIONS

Cer	Ceramic	m	milli or 10 <sup>-3</sup>
Comp.	Composition	Ω	ohm
EMC	Electrolytic, metal cased	PBT	Paper, "Bathtub"
f	Farad	PMC	Paper, metal cased
GMV	Guaranteed minimum value	Poly.	Polystyrene
h	Henry	Prec.	Precision
k	Kilohm or 10 <sup>3</sup> ohms	PT	Paper Tubular
M/Cer.	Mica or Ceramic	v	Working volts DC
meg	Megohm or 10 <sup>6</sup> ohms	Var.	Variable
μ	Micro. or 10 <sup>-6</sup>	w	Watt
μμ	Micromicro or 10 <sup>-12</sup>	WW	Wire-wound

### Special Notes and Symbols

+	and up.
†	Approximate serial number.
X000	Part first added at this serial number.
000X	Part removed after this serial number.
(Mod. w/)	Simple replacement not recommended. Modify to value for later instruments and change other listed parts to match.

							Order Parts by Number
Capacitors							
C201	101-2146	20 μf	450 v	Fixed	EMC	-20+50%	290-037
	2147 +	(1/2-2x20 μf) <sup>1</sup> 40 μf (2x20 μf)	450 v	Fixed	EMC	-20+50%	290-037
C202	101-2146X Replaced by C253	.01 μf	400 v	Fixed	PT	20%	285-510
C203	101-2146X (Substitute) Replaced by C252	.006 μf	500 v	Fixed	Mica	20%	Use 283-532
		.0068 μf	500 v	Fixed	Mica	10%	283-532
C204	101-2146X Replaced by C201	20 μf	450 v	Fixed	EMC	-20+50%	290-037
C205	101-165 †	0.25 μf	2000 v	Fixed	PMC	20%	Use 285-529
	166 † -577X	0.1 μf	2000 v	Fixed	PMC	20%	285-529
C205A	X578-2146X Replaced by C257	.05 μf	2000 v	Fixed	PMC	20%	285-523
		(1/2-2x.05 μf)					

<sup>1</sup> C201 and C204



Capacitors (continued)

C205B	X578-2146X	.05 $\mu$ f	2000 v	Fixed	PMC	20%	285-523
Replaced by C255		(1/2-2x.05 $\mu$ f)					
C205.1	X166-569	.05 $\mu$ f	2000 v	Fixed	PMC	20%	Mod w/C205
Replaced by C205B		(2x.05 $\mu$ f)	2000 v	Fixed	PMC	20%	285-523
C206	101-165 †	0.25 $\mu$ f	2000 v	Fixed	PMC	20%	Use 285-529
Replaced by C256		166 -2146X †	2000 v	Fixed	PMC	20%	285-529
C214	(Same as C205.1)						
C251	X2147 +	.001 $\mu$ f	600 v	Fixed	PT	20%	285-501
C252	X2147 +	.001 $\mu$ f	600 v	Fixed	PT	20%	285-501
C253	X2147 +	.001 $\mu$ f	600 v	Fixed	PT	20%	285-501
C254	X2147 +	.0068 $\mu$ f	3 kv	Fixed	PT	20%	285-508
C255	X2147 +	.0068 $\mu$ f	3 kv	Fixed	PT	20%	285-508
C256	X2147 +	.0068 $\mu$ f	3 kv	Fixed	PT	20%	285-508
C257	X2147 +	.015 $\mu$ f	3 kv	Fixed	PT	20%	285-513

Resistors

R201	101-2146X	15 k	2 w	Fixed	Comp.	10%	306-153
Replaced by R251							
R202	101-2146X	100 $\Omega$	1/2 w	Fixed	Comp.	10%	302-101
R203	101-2146X	100 k	1/2 w	Fixed	Comp.	10%	302-104
Replaced by R261							
R203.1	X302 +	47 $\Omega$	1/2 w	Fixed	Comp.	10%	302-470
R204	101-165	1 meg	1/2 w	Fixed	Comp.	10%	302-105
Replaced by R257		166-2146X	1/2 w	Fixed	Comp.	10%	302-273
R205	101-2146X	50 meg	2 w	Fixed	H.V.	10%	312-543
Replaced by R258, R259, R260.							
R251	X2147 +	22 k	2 w	Fixed	Comp.	10%	306-223

Resistors (continued)

R252	X2147 +	470 k	1/2 w	Fixed	Comp.	10%	302-474
R253	X2147 +	1.8 meg	1/2 w	Fixed	Comp.	10%	302-185
R254	X2147 +	2 meg	2 w	Var.	Comp.	20%	311-042
R255	X2147 +	4.7 meg	2 w	Fixed	Comp.	10%	306-475
R256	X2147 +	4.7 meg	2 w	Fixed	Comp.	10%	306-475
R257	X2147 +	1 k	1/2 w	Fixed	Comp.	10%	302-102
R258	X2147 +	22 meg	1/2 w	Fixed	Comp.	10%	302-226
R259	X2147 +	22 meg	1/2 w	Fxed	Comp.	10%	302-226
R260	X2147 +	22 meg	1/2 w	Fixed	Comp.	10%	302-226
R261	X2147 +	47 k	1/2 w	Fixed	Comp.	10%	302-473
R262	X2147 +	1.5 k	1/2 w	Fixed	Comp.	10%	302-152
R263	X2339	27 k	1/2 w	Fixed	Comp.	10%	302-273

Vacuum Tubes

V201	101 +	6AQ5	H.V. Supply Oscillator	154-017
V202	101-1204	1B3	+1500 v Rectifier	154-091
Replaced by V226		1V2	+1500 v Rectifier	154-004
V203	101-1204	1B3	-1500 v Rectifier	154-091
Replaced by V227		1V2	-1500 v Rectifier	154-004
V225	X2147 +	12AU7	DC Amplifier and H.V. Oscillator Screen Supply	154-041
V226	X2147 +	5642	+1500 v Rectifier	154-051
V227	X2147 +	5642	-1500 v Rectifier	154-051

Transformers

T202	101-2146X	2KC, H.V. Transformer, T5120A4(For 1B3 Rectifiers) T5120B1(For 1V2 Rectifiers)	120-018 120-019
Replaced by T226			



Transformers (continued)

Primary: 190 V Tapped at 25 V

Secondaries: 1250 VAC, 1 ma.  
 0.625 VAC, 3 A Connected to 1250 V winding  
 0.625 VAC, 3 A Insulated for 1500 VDC

T226 X2147 + 70 KC, H.V. Transformer, Type T5120C2 120-020

Primary: Approximately 200 V

Secondaries: 1250 VAC 1 ma.  
 1.25 VAC 200 ma.  
 1.25 VAC 200 ma.

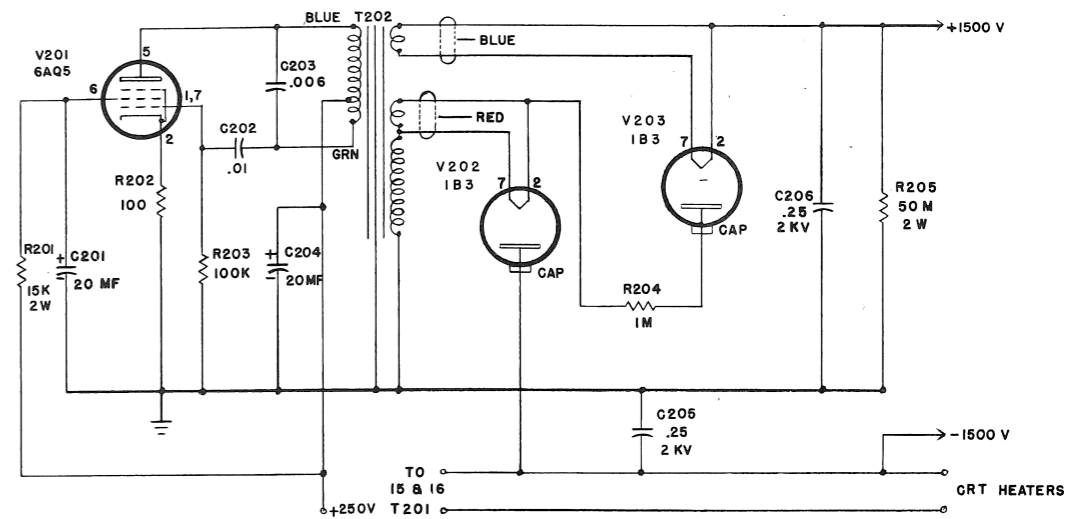

S/N 101-165 ONLY

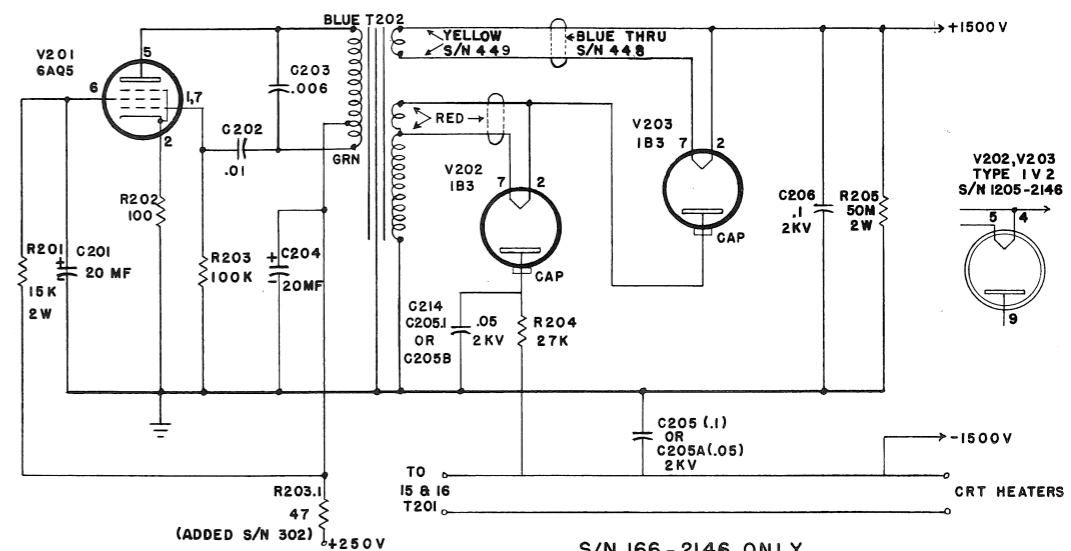

S/N 166-2146 ONLY

TYPE 512 H.V. SUPPLY  
 S/N 101 - 2146





#### NOTE

Unless otherwise specified, all of the voltage readings were taken with a dc vacuum-tube voltmeter having an input resistance of 11 megohms. The waveforms shown were reproduced from actual photographs. There will be considerable variation between instruments because of normal manufacturing tolerances and vacuum-tube characteristics. Therefore, the significance of any discrepancies observed should be determined by referring to the circuit diagram.

All readings are in volts unless otherwise specified. Where two voltage readings are given, they represent the voltage as read by a voltmeter under two sets of conditions, and, as such, do not indicate the peak-to-peak excursion of voltage at the point.

H.V. SUPPLY

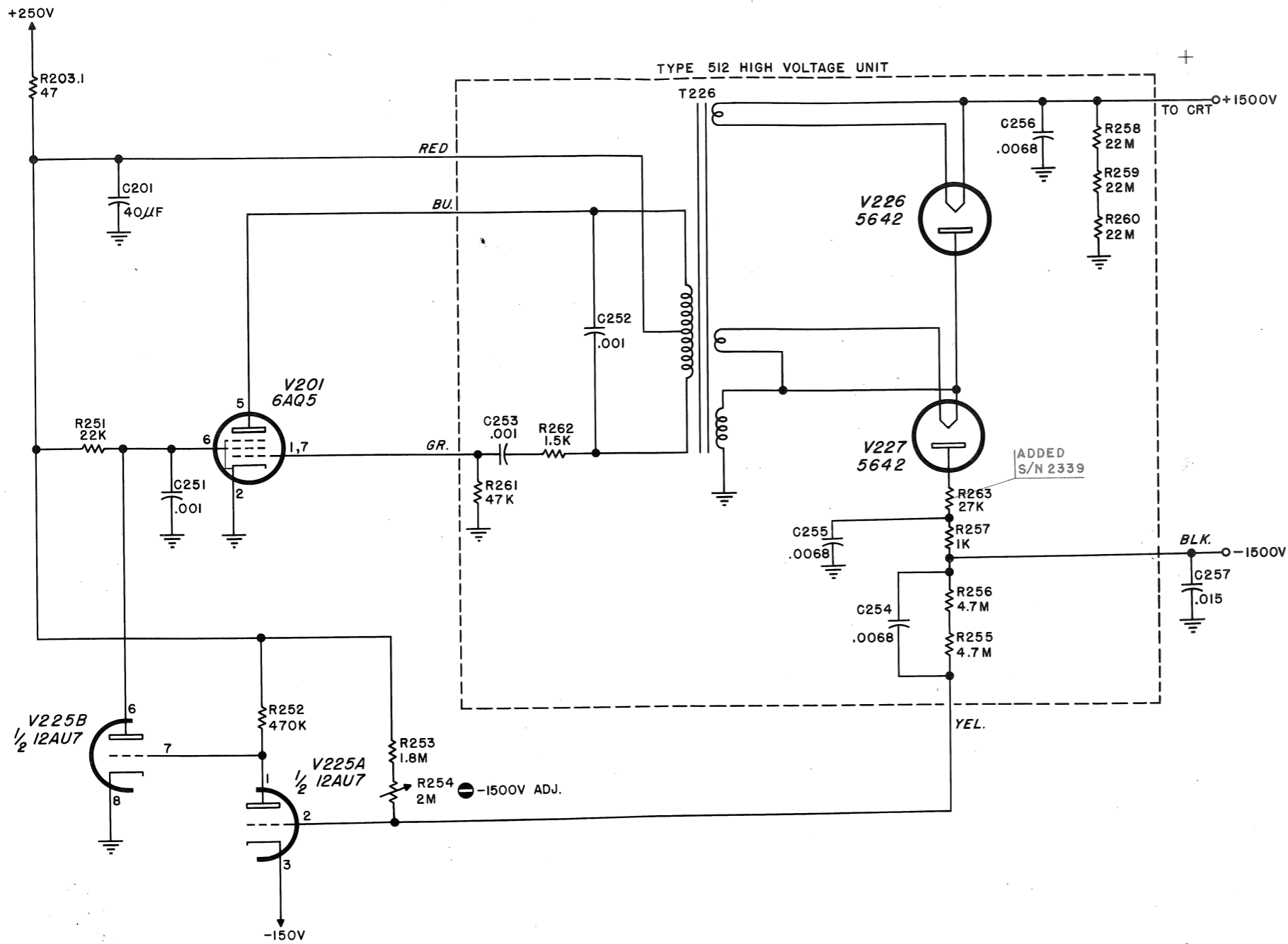

TYPE 512 OSCILLOSCOPE

L.A.P.  
7-31-53

A  
70KC H.V. SUPPLY  
S/N 2147 UP

MISCELLANEOUS PARTS

Access Panel Plug		134-012
Binding Post, Bakelite, 5-way		129-001
Bulb, #47		150-001
Bulb, Neon, NE-2, 60 v		150-010
Fuse, 3 a, Slo-Blo	4AG (S/N 101-2611) 3AG (S/N 2612 and up)	159-007 159-005
Graticule, 6 x 10 cm	(for 5CP7)	331-006
8 x 10 cm	(for 5ABP7)	331-010
Knob, 11/16" SCALE ILLUM. (1450-A)		366-511
Knob, 1", White Dot	(619-A)	366-510
Knob, Skirted, 1 1/2"	(380)	366-002
Knob, Dial Assembly, KN380A1, CALIBRATOR dial		366-507
Knob, Dial Assembly, KN380A2, SWEEP dial		366-508
Nut, Graticule		210-424
Power Cord, COP 18-8		161-001
Probe, P510A		010-001
Probe Tip--" Tektip"	(Hooked) (Straight) (Angle)	206-008 206-009 206-011
Receptacle, Coax		131-012
Receptacle, Power Cord		131-010

